

# Panasonic

## Network Disk Recorder Installation Guide

Model No. **WJ-ND300A**

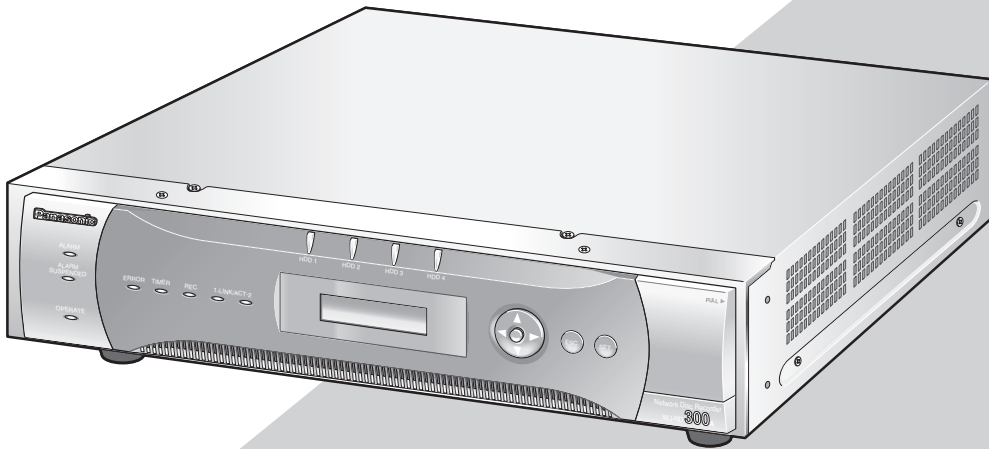

Before attempting to connect or operate this product,  
please read these instructions carefully and save this manual for future use.

We declare under our sole responsibility that the product to which this declaration relates is in conformity with the standards or other normative documents following the provisions of Directives EEC/73/23 and EEC/89/336.

Wir erklären in alleiniger Verantwortung, daß das Produkt, auf das sich diese Erklärung bezieht, mit der folgenden Normen oder normativen Dokumenten übereinstimmt. Gemäß den Bestimmungen der Richtlinie 73/23/EEC und 89/336/EEC.

Nous déclarons sous notre seule responsabilité que le produit auquel se réfère la présente déclaration est conforme aux normes ou autres documents normatifs conformément aux dispositions des directives CEE/73/23 et CEE/89/336.

Nosotros declaramos bajo nuestra única responsabilidad que el producto a que hace referencia esta declaración está conforme con las normas u otros documentos normativos siguiendo las estipulaciones de las directivas CEE/73/23 y CEE/89/336.

Noi dichiariamo sotto nostra esclusiva responsabilità che il prodotto a cui si riferisce la presente dichiarazione risulta conforme al seguente standard o altri documenti normativi conformi alle disposizioni delle direttive CEE/73/23 e CEE/89/336.

### WARNING:

- This apparatus must be earthed.
- Apparatus shall be connected to a mains socket outlet with a protective earthing connection.
- The mains plug or an appliance coupler shall remain readily operable.
- To prevent fire or electric shock hazard, do not expose this apparatus to rain or moisture.
- The apparatus should not be exposed to dripping or splashing and that no objects filled with liquids, such as vases, should be placed on the apparatus.
- All work related to the installation of this product should be made by qualified service personnel or system installers.
- The connections should comply with local electrical code.



**CAUTION**

RISK OF ELECTRIC SHOCK  
DO NOT OPEN



CAUTION: TO REDUCE THE RISK OF ELECTRIC SHOCK,  
DO NOT REMOVE COVER (OR BACK).  
NO USER-SERVICEABLE PARTS INSIDE.  
REFER SERVICING TO QUALIFIED SERVICE PERSONNEL.

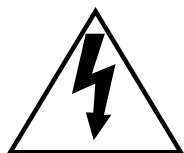

The lightning flash with arrowhead symbol, within an equilateral triangle, is intended to alert the user to the presence of uninsulated "dangerous voltage" within the product's enclosure that may be of sufficient magnitude to constitute a risk of electric shock to persons.



The exclamation point within an equilateral triangle is intended to alert the user to the presence of important operating and maintenance (servicing) instructions in the literature accompanying the appliance.



Power disconnection. Unit with or without ON-OFF switches have power supplied to the unit whenever the power cord is inserted into the power source; however, the unit is operational only when the ON-OFF switch is in the ON position. The power cord is the main power disconnect for all units.

Wij verklaren als enige aansprakelijke, dat het product waarop deze verklaring betrekking heeft, voldoet aan de volgende normen of andere normatieve documenten, overeenkomstig de bepalingen van Richtlijnen 73/23/EEC en 89/336/EEC.

Vi erklærer os eneansvarlige for, at dette produkt, som denne deklaration omhandler, er i overensstemmelse med standarder eller andre normative dokumenter i følge bestemmelserne i direktivene 73/23/EEC og 89/336/EEC.

Vi deklarerar härmed vårt fulla ansvar för att den produkt till vilken denna deklaration hänvisar är i överensstämmelse med standarddokument, eller andra normativa dokument som framställs i EEC-direktiv nr. 73/23 och 89/336.

Ilmoitamme yksinomisella vastuullamme, että tuote, jota tämä ilmoitus koskee, noudattaa seuraavia standardeja tai muita ohjeellisia asiakirjoja, jotka noudattavat direktiivien 73/23/EEC ja 89/336/EE. säädöksiä.

Vi erklærer oss alene ansvarlige for at produktet som denne erklæringen gjelder for, er i overensstemmelse med følgende normer eller andre normgivende dokumenter som følger bestemmelsene i direktivene 73/23/EEC og 89/336/EEC.



### For U.K.

#### FOR YOUR SAFETY PLEASE READ THE FOLLOWING TEXT CAREFULLY.

This appliance is supplied with a moulded three pin mains plug for your safety and convenience.

A 5 amp fuse is fitted in this plug.

Should the fuse need to be replaced please ensure that the replacement fuse has a rating of 5 amp and that it is approved by ASTA or BSI to BS1362.

Check for the ASTA mark  or the BSI mark  on the body of the fuse.

If the plug contains a removable fuse cover you must ensure that it is refitted when the fuse is replaced.

If you lose the fuse cover the plug must not be used until a replacement cover is obtained.

A replacement fuse cover can be purchased from your local Panasonic Dealer.

**IF THE FITTED MOULDED PLUG IS UNSUITABLE FOR THE SOCKET OUTLET IN YOUR HOME THEN THE FUSE SHOULD BE REMOVED AND THE PLUG CUT OFF AND DISPOSED OF SAFELY. THERE IS A DANGER OF SEVERE ELECTRICAL SHOCK IF THE CUT OFF PLUG IS INSERTED INTO ANY 13 AMP SOCKET.**

If a new plug is to be fitted please observe the wiring code as shown below.

If in any doubt please consult a qualified electrician.

**WARNING: This apparatus must be earthed.**

#### IMPORTANT

The wires in this mains lead are coloured in accordance with the following code.

Green-and-yellow:	Earth
Blue:	Neutral
Brown:	Live

As the colours of the wire in the mains lead of this appliance may not correspond with the coloured markings identifying the terminals in your plug, proceed as follows.

The wire which is coloured **green-and-yellow** must be connected to the terminal in the plug which is marked with the letter **E** or by the earth symbol  or coloured **green** or **green-and-yellow**.

The wire which is coloured **blue** must be connected to the terminal in the plug which is marked with the letter **N** or coloured **black**.

The wire which is coloured **brown** must be connected to the terminal in the plug which is marked with the letter **L** or coloured **red**.

#### How to replace the fuse

Open the fuse compartment with a screwdriver and replace the fuse and fuse cover.

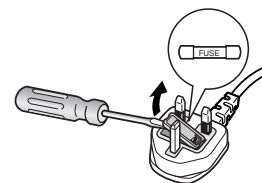

The serial number of this product may be found on the surface of the unit.

You should note the serial number of this unit in the space provided and retain this book as a permanent record of your purchase to aid identification in the event of theft.

Model No. \_\_\_\_\_

Serial No. \_\_\_\_\_

For Canada

This Class A digital apparatus complies with Canadian ICES-003.

For U.S.A

NOTE: This equipment has been tested and found to comply with the limits for a Class A digital device, pursuant to Part 15 of the FCC Rules. These limits are designed to provide reasonable protection against harmful interference when the equipment is operated in a commercial environment. This equipment generates, uses, and can radiate radio frequency energy and, if not installed and used in accordance with the instruction manual, may cause harmful interference to radio communications.

Operation of this equipment in a residential area is likely to cause harmful interference in which case the user will be required to correct the interference at his own expense.

FCC Caution: To assure continued compliance, (example - use only shielded interface cables when connecting to computer or peripheral devices). Any changes or modifications not expressly approved by the party responsible for compliance could void the user's authority to operate this equipment.

## Limitation of Liability

THIS PUBLICATION IS PROVIDED "AS IS" WITHOUT WARRANTY OF ANY KIND, EITHER EXPRESS OR IMPLIED, INCLUDING BUT NOT LIMITED TO, THE IMPLIED WARRANTIES OF MERCHANTABILITY, FITNESS FOR ANY PARTICULAR PURPOSE, OR NON-INFRINGEMENT OF THE THIRD PARTY'S RIGHT.

THIS PUBLICATION COULD INCLUDE TECHNICAL INACCURACIES OR TYPOGRAPHICAL ERRORS. CHANGES ARE ADDED TO THE INFORMATION HEREIN, AT ANY TIME, FOR THE IMPROVEMENTS OF THIS PUBLICATION AND/OR THE CORRESPONDING PRODUCT (S).

## Disclaimer of Warranty

IN NO EVENT SHALL MATSUSHITA ELECTRIC INDUSTRIAL CO., LTD. BE LIABLE TO ANY PARTY OR ANY PERSON, EXCEPT FOR REPLACEMENT OR REASONABLE MAINTENANCE OF THE PRODUCT, FOR THE CASES, INCLUDING BUT NOT LIMITED TO BELOW:

- (1) ANY DAMAGE AND LOSS, INCLUDING WITHOUT LIMITATION, DIRECT OR INDIRECT, SPECIAL, CONSEQUENTIAL OR EXEMPLARY, ARISING OUT OF OR RELATING TO THE PRODUCT;
- (2) PERSONAL INJURY OR ANY DAMAGE CAUSED BY INAPPROPRIATE USE OR NEGLIGENT OPERATION OF THE USER;

- (3) UNAUTHORIZED DISASSEMBLE, REPAIR OR MODIFICATION OF THE PRODUCT BY THE USER;
- (4) ANY PROBLEM, CONSEQUENTIAL INCONVENIENCE, OR LOSS OR DAMAGE, ARISING OUT OF THE SYSTEM COMBINED BY THE DEVICES OF THIRD PARTY.
- (5) ANY CLAIM OR ACTION FOR DAMAGES, BROUGHT BY ANY PERSON OR ORGANIZATION BEING A PHOTOGENIC SUBJECT, DUE TO VIOLATION OF PRIVACY WITH THE RESULT OF THAT SURVEILLANCE-CAMERA'S PICTURE, INCLUDING SAVED DATA, FOR SOME REASON, BECOMES PUBLIC OR IS USED FOR THE PURPOSE OTHER THAN SURVEILLANCE.

# Important Safety Instructions

- 1) Read these instructions.
- 2) Keep these instructions.
- 3) Heed all warnings.
- 4) Follow all instructions.
- 5) Do not use this apparatus near water.
- 6) Clean only with dry cloth.
- 7) Do not block any ventilation openings. Install in accordance with the manufacturer's instructions.
- 8) Do not install near any heat sources such as radiators, heat registers, stoves, or other apparatus (including amplifiers) that produce heat.
- 9) Do not defeat the safety purpose of the polarized or grounding-type plug. A polarized plug has two blades with one wider than the other. A grounding type plug has two blades and a third grounding prong. The wide blade or the third prong are provided for your safety. If the provided plug does not fit into your outlet, consult an electrician for replacement of the obsolete outlet.
- 10) Protect the power cord from being walked on or pinched particularly at plugs, convenience receptacles, and the point where they exit from the apparatus.
- 11) Only use attachments/accessories specified by the manufacturer.
- 12) Use only with the cart, stand, tripod, bracket, or table specified by the manufacturer, or sold with the apparatus. When a cart is used, use caution when moving the cart/apparatus combination to avoid injury from tip-over.



- 13) Unplug this apparatus during lightning storms or when unused for long periods of time.
- 14) Refer all servicing to qualified service personnel. Servicing is required when the apparatus has been damaged in any way, such as power-supply cord or plug is damaged, liquid has been spilled or objects have fallen into the apparatus, the apparatus has been exposed to rain or moisture, does not operate normally, or has been dropped.

# CONTENTS

Limitation of Liability .....	3
Disclaimer of Warranty .....	3
Important Safety Instructions .....	4
Precautions .....	6
Trademarks and Registered Trademarks .....	8
About these Operating Instructions .....	8
Network Security .....	8
Preface .....	9
Features .....	9
Major Operating Controls and Their Functions .....	10
■ Front View .....	10
■ Rear View .....	11
Rack Mounting .....	12
Connections .....	13
Connection Type .....	13
Connection between cameras and PCs .....	14
Connecting with Extension Unit .....	16
■ How to Use the Terminals of the ALARM/CONTROL Connector .....	18
■ How to Use the Terminals of the ALARM Connector .....	22
How to Replace Hard Disk Drives .....	24
Turn On/Off the Power of the Unit .....	27
Operating the Unit for the First Time .....	27
Turn on the Power of the Unit .....	27
Turn off the Power of the Unit .....	28
Operation Using the Buttons on the Front Panel .....	29
Check the Network Settings .....	30
Set the Network Settings .....	31
Key Lock Settings .....	32
Set the HDD Mode .....	32
Set the HDD Safety Mode .....	34
Check the Unit Number of the Extension Unit .....	35
Reboot the Unit Manually .....	36
Troubleshooting .....	37
Specification .....	39
Standard accessories .....	39

# Precautions

- **Refer all work related to the installation of this product to qualified service personnel or system installers.**

- **Do not operate the unit beyond their its specified temperature, humidity, or power source ratings.**

Use the unit at temperatures between +5 °C - +45 °C {41 °F - 113 °F} and where the humidity is between 5 % - 90 %.

The input power source for NTSC model is 120 V AC 60 Hz, for PAL model is 220 V - 240 V AC 50 Hz.

Performance and lifetime of hard disk drives are easily affected by heat (used at high temperature) characteristically. It is recommended to use this unit at temperatures between +20 °C - +30 °C {68 °F - 86 °F}.

- **POWER switch**

The POWER switch is located on the rear of the unit. Even though the POWER switch is set to "OFF", the power supply will not be cut. To cut the power supply, unplug the power plug of the unit from the AC outlet. When using the power supply control unit, turn off the power of the power supply control unit.

- **Built-in backup battery**

Before the first use, charge the built-in backup battery (lithium battery) by turning on the power for 48 hours or more.

If it is not charged enough, in a case where the power goes down, the internal clock may keep bad time or the operative condition may be different to that before the electric power failure.

The built-in battery life is approximately 5 years as an indication of replacement. (This is just an indication of replacement. We are not providing any guarantee of the built-in battery lifetime. Replacement cost of the built-in battery is not covered by the warranty even if it needs to be done within the warranty period.) Ask the shop where you purchased the unit when replacement of the battery is required.

- **Built-in hard disk drives**

Hard disk drives are vulnerable to vibration. Handle them with care.

It is possible to damage them if they are moved while their motors are still running. Do not move them just after turning their power on or off (for around 30 seconds).

When hard disk drive trouble occurs, replace it immediately. Consult your dealer for servicing.

When replacing the hard disk drives, take notice of the following.

- Protect the hard disk drives from static electricity.
- Do not stack them, or keep them upright.
- Do not use an electric screwdriver to fix them. (Tightening torque: Approx. 0.49 N · m {5 kgf · cm})

- Avoid rapid changes of the temperature/humidity to prevent condensation. (Acceptable change: within 15 °C/h {59 °F/h})

- **Heat dissipation**

Refer to the following to prevent fire and malfunction of the unit.

- Do not block the ventilation openings in the cover to prevent the unit from overheating. Maintain the unit periodically to prevent dust from blocking openings.
- Clear a space of more than 5 cm {1.97"} from both sides, the top, and the rear of the unit.
- The cooling fan is perishable. Contact your dealer for servicing.

- **Grounding**

Confirm that the wire is connected from the SIGNAL GND terminal to earth ground.

A grounding connection must be made before connecting the power plug of the unit to the main power supply. When disconnecting the grounding wire, make sure that the power plug of the unit is disconnected from the main power supply.

- **Avoid placing the unit near noise sources**

If the unit is placed near noise sources such as fluorescent lamps, noises may be produced. In this case, rewire avoiding the noise sources, or move the unit to the place far from them.

- **Places to avoid**

Do not place the unit in the following places:

- Places exposed to direct sunlight
- Places subject to having strong vibration or impact
- Near magnetic field sources such as a television or speakers
- Place where condensation forms easily, where temperature changes greatly, humid places
- Steamy and oily places such as kitchens
- Places which are not level

- **Cleaning**

Turn the power off when cleaning the unit. Otherwise it may cause injuries.

Do not use strong or abrasive detergents when cleaning the unit body.

Use a dry cloth to clean the unit when it is dirty.

When the dirt is hard to remove, use a mild detergent and wipe gently.

- **Indication label**

Refer to the indication label placed on the surface of the unit as to the indications of equipment classification and power source, etc.

- **Handle the unit with care.**

Do not strike or shake, as this may damage the unit.

- **Do not strike or give a strong shock to the unit.**

It may cause damage or allow water to enter the unit.

- **Place the unit horizontally on a level surface.**

Do not place the unit in an upright position. When stacking multiple units, clear a space of more than 5 cm {1.97"} from both sides, the top, the bottom and the rear of the units.

- **Avoid placing receptacles that contain liquids such as water near the unit.**

If liquid spills onto the unit, it may cause fire or an electric shock.

- **Prevent condensation from forming on the surface of the hard disk.**

If this happens, do not turn on the power of the recorder and leave the recorder for around 2 hours.

Wait until the dew evaporates in any of the following cases:

- The recorder is placed in an extremely humid place.
- The recorder is placed in a room where a heater has just been turned on.
- The recorder is moved from an air-conditioned room to a humid and high-temperature room.

- When the unit has not been used for a certain period, turn on the power of the unit (approximately once a week), and perform recording/playback to prevent interferences with functions.

- We recommend that you make a note of your settings and save them. This will help when you are required to change the system configuration, or when unexpected trouble or failure occurs.

- Distributing, copying, disassembling, reverse compiling, reverse engineering, and also exporting in violation of export laws of the software provided with this product, is expressly prohibited.

- **MPEG-4 Visual patent portfolio license**

This product is licensed under the MPEG-4 Visual patent portfolio license for the personal and non-commercial use of a consumer for (i) encoding video in compliance with the MPEG-4 Visual Standard ("MPEG-4 Video") and/or (ii) decoding MPEG-4 Video that was encoded by a consumer engaged in a personal and non-commercial activity and/or was obtained from a video provider licensed by MPEG LA to provide MPEG-4 Video. No license is granted or shall be implied for

any other use. Additional information including that relating to promotional, internal and commercial uses and licensing may be obtained from MPEG LA, LLC. See <http://www.mpegla.com>.

Distributing, copying, disassembling, reverse compiling, reverse engineering, and also exporting in violation of export laws of the software provided with this product, is expressly prohibited.

## Trademarks and Registered Trademarks

- Adobe, Adobe logos, and Acrobat are registered trademarks of Adobe Systems Incorporated in the U.S. and/or other countries.
- Microsoft, Windows and Windows XP are registered trademarks of Microsoft Corporation in the U.S. and/or other countries.
- Other names of companies and products contained in these operating instructions may be trademarks or registered trademarks of their respective owners.

## About these Operating Instructions

There are 3 sets of operating instructions for the WJ-ND300A as follows.

- Installation Guide (this book)
- Operating Instructions (PDF)
- Setup Instructions (PDF)

The "Installation Guide" contains descriptions of how to install/connect this unit, and descriptions of how to operate this unit with the buttons on the front panel.

Refer to the "Operating Instructions" on the provided CD-ROM for descriptions of how to operate this unit with a PC.

Refer to the "Setup Instructions" on the provided CD-ROM for descriptions of how to perform the required settings and how to connect to other devices.

Adobe® Reader is required to read the "Operating Instructions" and the "Setup Instructions" on the provided CD-ROM. When the Adobe® Reader is not installed on the PC, download the latest Adobe® Reader from the Adobe web site and install it.

"WJ-ND300A" or "ND300A" shown in the illustrations used in these operating instructions indicate this unit or the WJ-ND300A series.

## Network Security

As you will use this product connected to a network, your attention is called to the following security risks.

1. Leakage or theft of information through this product
2. Use of this product for illegal operations by persons with malicious intent
3. Interference with or stoppage of this product by persons with malicious intent

It is your responsibility to take precautions such as those described below to protect yourself against the above network security risks.

- Use this product in a network secured by a firewall, etc.
- If this product is connected to a network that includes PCs, make sure that the system is not infected by computer viruses or other malicious entities (using a regularly updated anti-virus program, anti-spyware program, etc.).
- Protect your network against unauthorized access by restricting users to those who log in with an authorized user name and password.
- Apply measures such as user authentication to protect your network against leakage or theft of information, including image data, authentication information (user names and passwords), alarm mail information, FTP server information and DDNS server information.



# Preface

The Network Disk Recorders WJ-ND300A is designed for use within a surveillance system.

The network disk recorder is a recording device using a hard disk drive to record pictures of network cameras instead of using videotapes so that pictures recorded by repeated overwriting will not experience deterioration of the recorded picture quality. Up to 32 cameras can be connected to the WJ-ND300A via a network and it is possible to record their camera pictures. It is possible to perform the settings or operate the unit using a web browser installed on a PC when this unit is connected to a network.

## Features

### Various Recording Functions

- **Multi-Recording**

It is possible to perform multiple recordings using a single digital disk recorder even if the operating environments are different, for example, recording pictures of cameras in different places with different recording rates.

- **Schedule recording**

It is possible to perform recording automatically at a scheduled time on a designated day of the week. It is also possible to apply different recording settings, such as the recording rate, by the schedule time.

- **Emergency Recording**

In the case of an emergency, emergency recordings will be given a higher priority than other recording modes by operating an external switch.

- **External Timer Recording**

It is possible to perform recording automatically using an external timer.

- **Event Recording**

At an event occurrence, such as when an alarm signal is supplied, the recording rate can be changed.

### Downloading/Transmitting Images

It is possible to download (save) the currently displayed image in the web browser window onto the hard disk of a PC. By establishing an FTP server, it is possible to transmit images to a designated FTP server. When an event occurs, it is possible to transmit images from the camera installed in the place where the event occurred.

### Security Function and Reliability

- Authentication function (registration of ID and password) allows users access to a predetermined selection of the available functions. Up to 32 users can be registered.
- If a hard disk crashes, the RAID 5 function (\*1) prevents any data loss.
  - \*1: To use the RAID 5 function, an optional extension unit is required.

### Host Authentication

It is possible to restrict devices from operating this unit if their IP addresses are not registered.

# Major Operating Controls and Their Functions

## ■ Front View

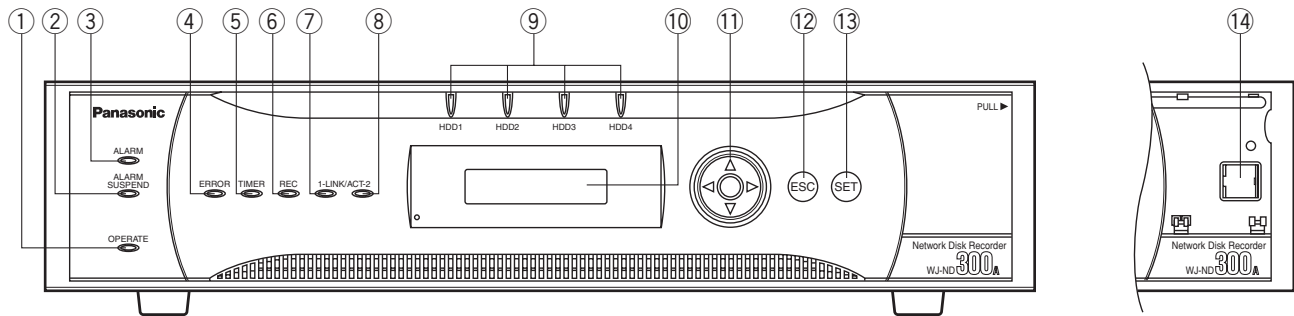

### ① Operate Indicator (OPERATE)

Lights up when the power is turned on.

### ② Alarm Suspension Indicator (ALARM SUSPEND)

Lights up when the alarm suspension mode is selected. Refer to the Operating Instructions about the alarm suspension mode.

### ③ Alarm Indicator (ALARM)

Blinks when an alarm occurs. The blinking or lighting indicator will go off when the alarm is reset.

### ④ Error indicator (ERROR)

Blinks orange when an error occurs that will not keep the unit from running. (e.g. thermal error, cooling fan malfunction, etc.)  
Blinks red when an error occurs that may cause the system to go down.  
Refer to the Operating Instructions about error/ warnings.

### ⑤ Timer Indicator (TIMER)

Lights up when the schedule recording is set, and blinks while the schedule recording is being performed.

### ⑥ Recording Indicator (REC)

Lights up when recording is being performed.

### ⑦ Camera Link Indicator (LINK/ACT1)

Lights green when the communication between a camera and the unit is established.  
Blinks green when receiving data from a camera.

### ⑧ PC Link Indicator (LINK/ACT2)

Lights green when the communication between a PC and the unit is established.  
Blinks green when receiving data from a PC.

### ⑨ HDD Access Indicators (HDD1/HDD2/HDD3/HDD4)

Indicates the statuses of the hard disks.  
Blinks green when the hard disk is accessed respectively.  
When using the RAID 5 function (\*1), these indicators will display the statuses as follows when an error occurs.

**Lights red:** Indicates that the respective hard disk is the first drive that had an error.

**Blinks red:** Indicates that the respective hard disk is the second drive that had an error.

**Lights red and orange alternately:** Indicates that the respective hard disk is currently being recovered in the RAID 5 mode (\*1).

\*1: The RAID 5 function/mode is available only when an optional RAID card is installed and configured. Refer to the dealer for details.

**Note:** Basically, each indicator will indicate the status of the respective hard disk (HDD1/HDD2/HDD3/HDD4). However, all indicators will indicate the same status when a system error occurs.

**Important:** When the indicator lights red, replace the respective hard disk immediately.

If 2 HDD access indicators or more light/blink red, it may be impossible to recover data on the respective hard disks.

Refer to page 24 for descriptions of how to replace the hard disk.

### ⑩ LCD

Indicates the status of the unit (error status, etc.) or the name of the functions available using the buttons on the front panel of the unit.

### ⑪ Arrow Buttons (▼, ▲, ◀, ▶)

Use these buttons to move the cursor or to enter values on the LCD.

- ⑫ **Escape Button (ESC)**  
Use this button to display the previously displayed item on the LCD.
- ⑬ **Set Button (SET)**  
Use this button to determine the edited settings item on the LCD.
- ⑭ **Maintenance Port (For servicing purpose only)**  
Use this port to connect directly with a PC and perform maintenance operations. (Straight cable is required.)

## ■ Rear View

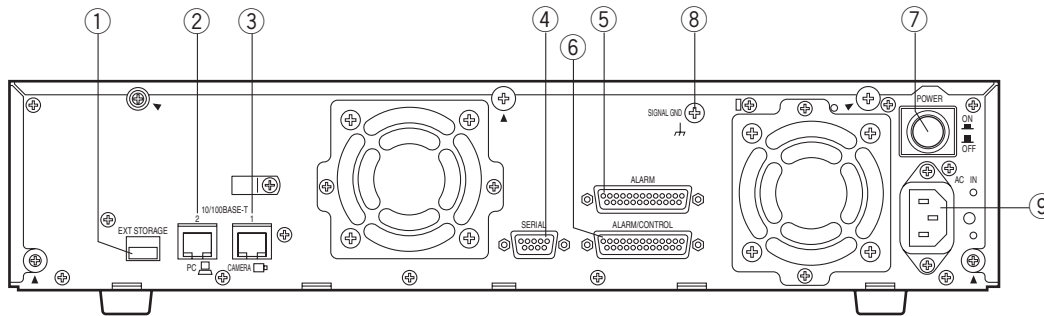

- ① **External Storage Connector (EXT STORAGE)**  
Connect an optional extension unit (WJ-HDE300 series) with this port.
- ② **Client PC Port (PC, 10/100BASE-T, 2)**  
Connect this unit to a network compatible with 10BASE-T or 100BASE-Tx to connect a PC via a network.
- ③ **Camera Port (CAMERA, 10/100BASE-T, 1)**  
Connect this unit to a network compatible with 10BASE-T or 100BASE-Tx to connect to cameras via a network.
- ④ **Serial Connector (SERIAL, D-sub 9-pin, Female) (For servicing purpose only)**
- ⑤ **Alarm Connector (ALARM, D-sub 25-pin, Female)**  
Connect an external device such as a sensor or a door switch with this D-sub 25-pin connector.
- ⑥ **Alarm/Control Connector (ALARM/CONTROL)**  
Connect a control switch with this D-sub 25-pin connector when controlling this unit using an external device, or when controlling an alarm device such as a buzzer or a lamp.
- ⑦ **Power Switch (POWER)**  
Turns the power of this unit on and off.
- ⑧ **Signal Ground Terminal (SIGNAL GND)**
- ⑨ **Power Cord Inlet (AC IN)**  
Connect the power cord to this inlet.

# Rack Mounting

## Important:

When installing the unit in the rack without turning the power of the unit off, activate the HDD safety mode. (Refer to page 34 for further information.)

## Important

- Do not install the unit above an appliance which generates heat such a power amplifier. When installing the unit below a heat-generating appliance, install it below the appliance with a space equivalent to about 1 unit (44 mm {1.73"}) separating them.
- Keep the temperature in the rack below +45 °C {113 °F}. It is recommended to install cooling fans or equivalent equipment to keep the temperature in the rack below +30 °C {86 °F}.

1. Remove the four rubber feet from the bottom of the unit using a flathead screwdriver.

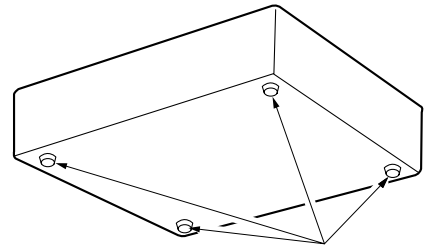

Remove the rubber feet.

2. Place the provided rack mounting brackets on both sides of the unit and tighten with the four provided screws.

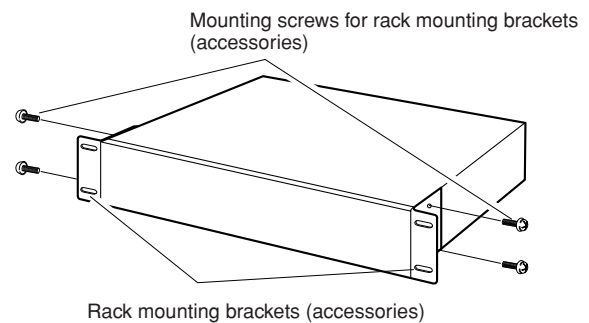

Mounting screws for rack mounting brackets (accessories)

Rack mounting brackets (accessories)

3. Install the unit with the rack mounting brackets in the rack by using four rack mounting screws.

## Cautions:

- Make a space of 1U (44 mm {1.73"}) above and below the unit for ventilation.
- Keep the temperature in a rack below 45 °C {113 °F}.
- Install a fan in the rack when the ambient temperature is above 30 °C {86 °F}.
- Do not block the ventilation openings or slots on the cover to prevent the unit from overheating.

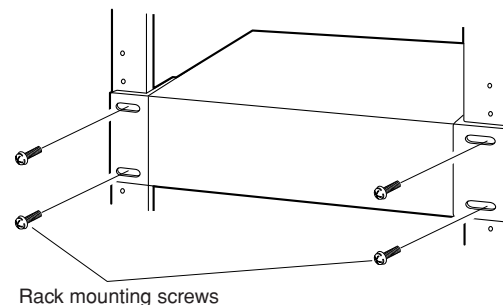

Rack mounting screws

# Connections

The following are descriptions of how to connect the unit with PCs, cameras and an optional extension unit.

Required devices and cables vary depending on how to connect them. Before starting the connections, check the required devices and cables for your environment.

The connection should be done in the following order:

PC → Cameras → Extension unit

## Connection Type

### Mode B

#### (Direct connection example: When using hubs)

Connect cameras and PCs using the CAMERA port and the client PC port on the rear of the unit respectively as shown in the illustration below.

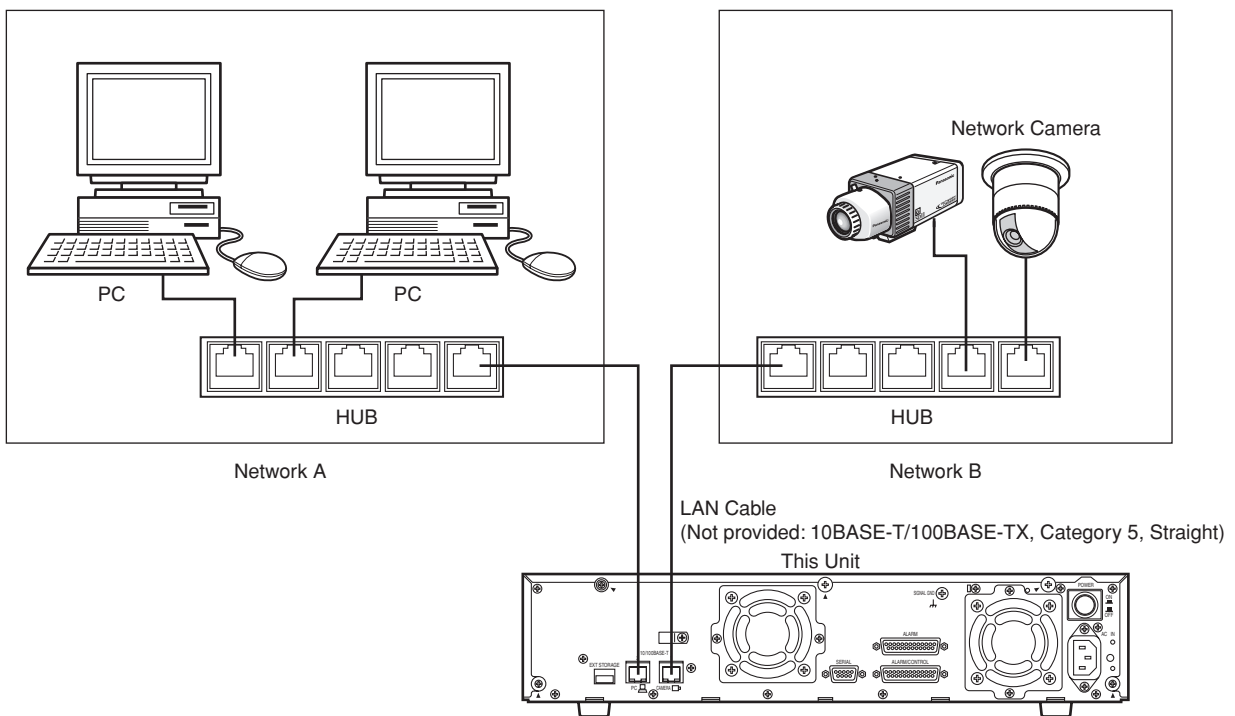

Images (video signals) from cameras will be supplied (input) to the CAMERA port, and the supplied images will be transmitted (output) to PCs.

**Important:** Do not connect PCs to a network to which the CAMERA port is connecting. Otherwise, transmission efficiency may be down.

Do not connect any camera to a network to which the client PC port is connecting for the same reason.

## Connection between cameras and PCs

When connecting the unit and PCs through a hub, use a LAN cable to connect between the unit and a hub. Cameras should also be connected through a hub using LAN cables.

**Important:** When connecting the unit and a PC directly without using a hub, connect them using a cross LAN cable.

## Connection Example

### <Connecting PCs using an ADSL line>

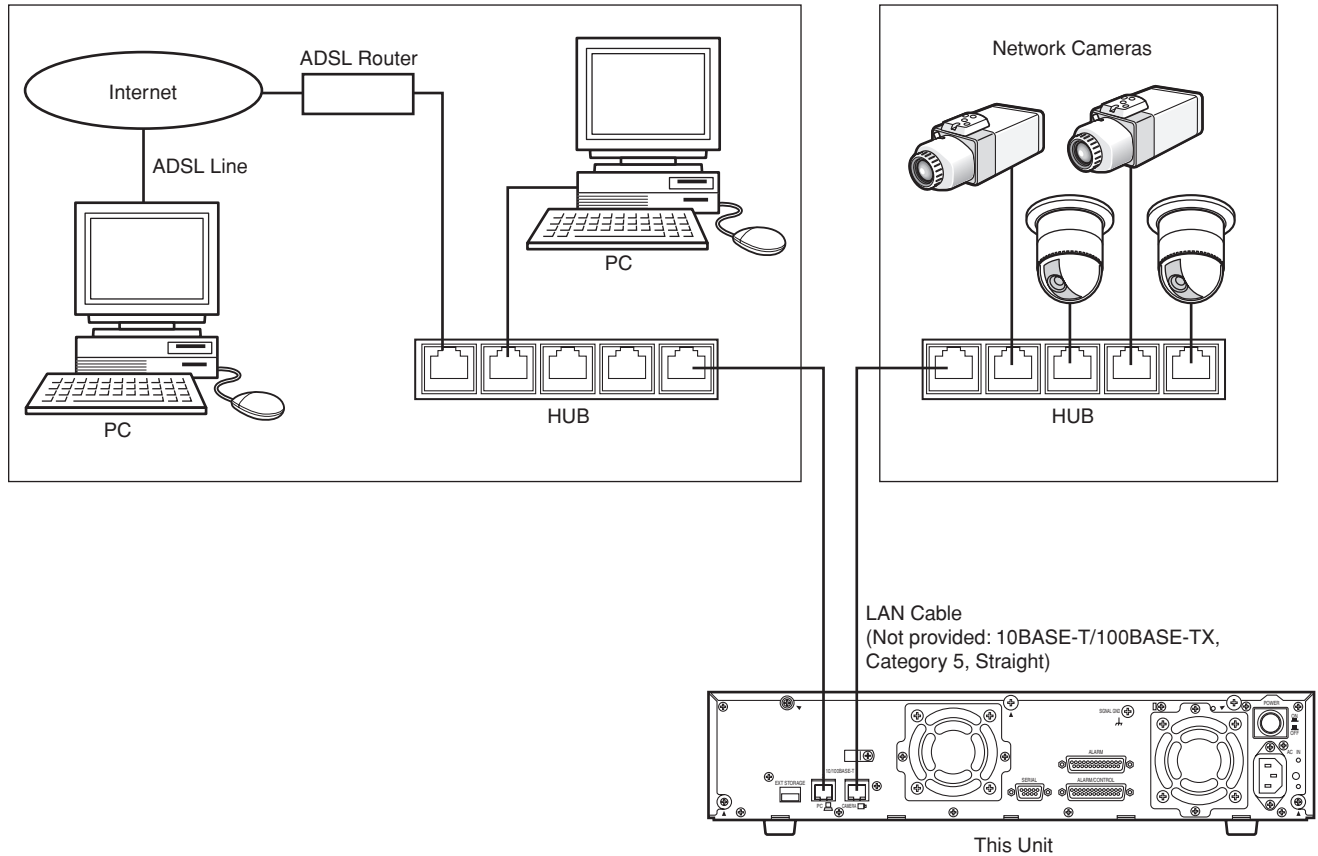

**Note:** When using a router, MPEG-4 images sometimes may not be displayed. Refer to the network administrator for how to configure the settings of the router.

<Connecting multiple units>

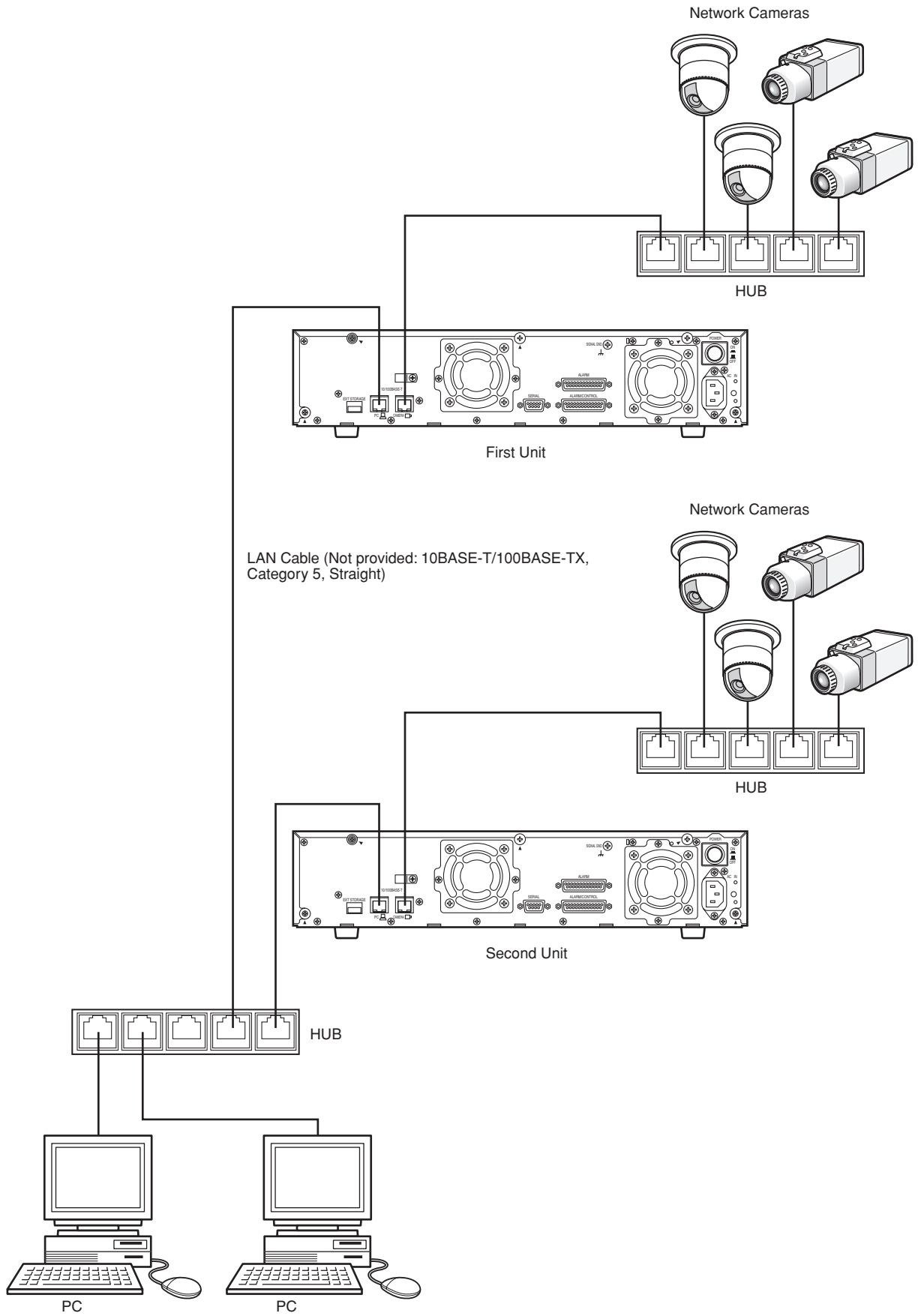

# Connecting with Extension Unit

Up to 6 extension units can be connected with a single network disk recorder.

Use the dedicated cable to connect between the external storage (EXT STORAGE) connector on the rear of the unit and an extension unit.

### Important:

- Use only the dedicated cable provided with an optional extension unit when connecting the unit and an extension unit.
- Fix the cables with this cable clamp to prevent disconnection or unstable connections that may cause recording failures or an unstable system.

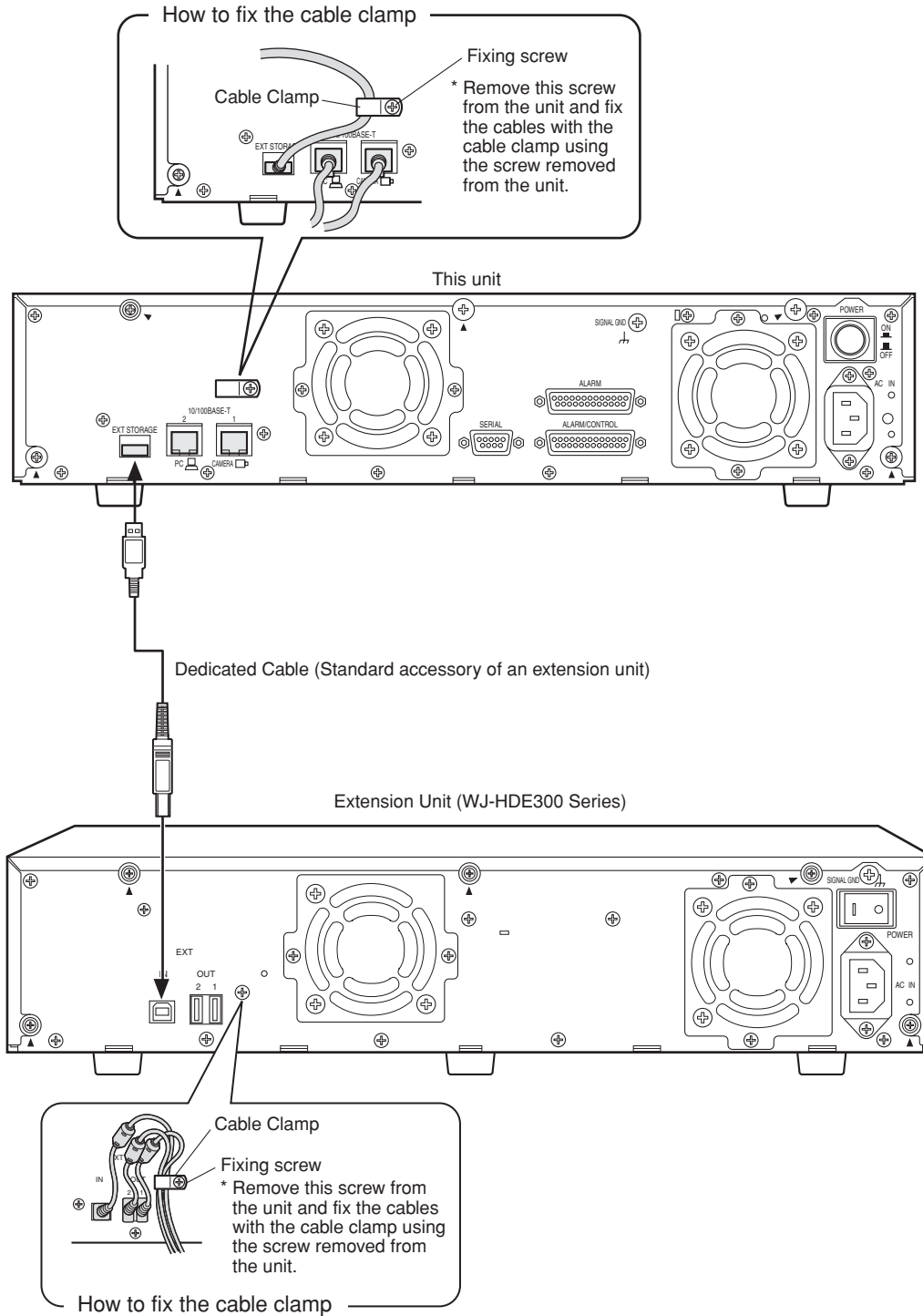



When connecting two extension units or more, connect them as follows. Up to 6 extension units can be connected to a single unit. When connecting the units newly, observe the following important notice. Refer also to the operating instructions of the extension unit.

**Important:**

- When connecting extension units, connect them as shown in the illustration below. When connected in a different way, the unit numbers may not be distributed correctly. In this case, the units may not be recognized correctly.  
**Example:** When installing 5 extension units, connect the unit of unit number 1 first, and then connect the other unit in the order of the unit number. When adding an extension unit, connect the unit of unit number 6 as described in the illustration.
- After running the system with the extension units, do not change the connection such as exchanging the unit numbers between the units. Otherwise, the unit numbers may not be distributed correctly and the units may not be recognized correctly.
- Refer to page 35 for how to check the unit number of the connected extension unit.

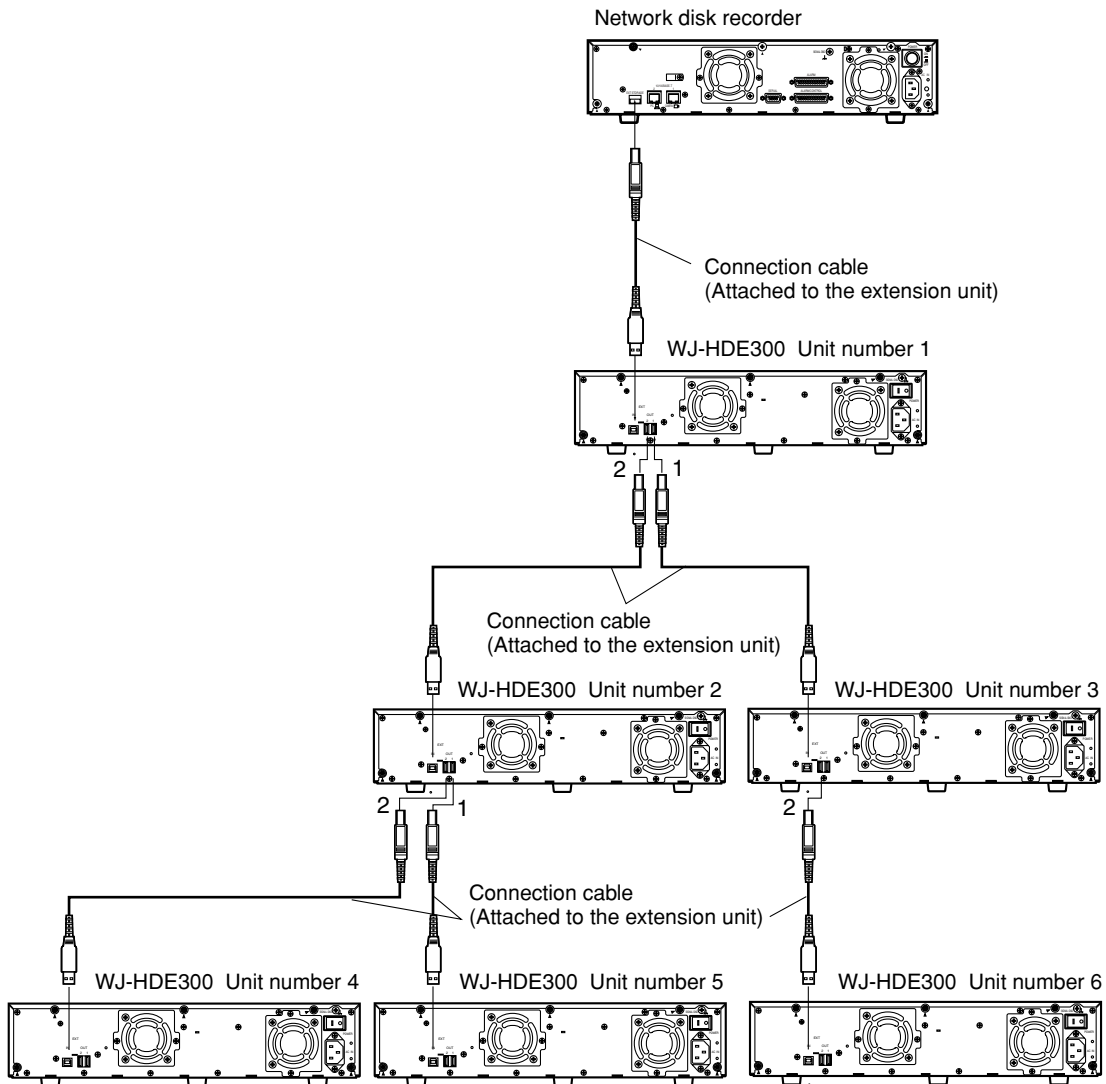

## ■ How to Use the Terminals of the ALARM/CONTROL Connector

These terminals are used for emergency recording, auto time adjustment, taking measures against power outages, and when installing a buzzer, a lamp, or similar alarm device.

The terminal pin array and connections are shown below. The connector used should be compatible with the pin configuration.

### Pin Configuration

The pin array is different from other disk recorders. Make sure that the connection is correct referring to the following.

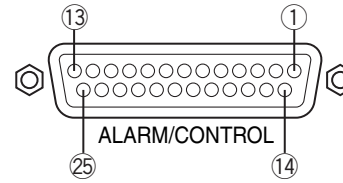

Pin No.	Signal	Operation	Remarks
①	Alarm output 8	Alarm signal output at an event occurrence	Open collector output 24 V DC max., 100 mA
②	Alarm output 9		
③	Alarm output 10		
④	Alarm output 11		
⑤	Alarm output 12		
⑥	Alarm output 13		
⑦	Alarm output 14		
⑧	Alarm output 15		
⑨	Alarm output 16		
⑩	Network error output	Signal output upon detection of a broken Ethernet link Signal output upon DHCP IP address expiration	Open collector output 24 V DC max., 100 mA
⑪	Alarm reset input	Canceling the alarm display	Non-voltage make contact input 5 V pull-up 150 kΩ
⑫	Emergency recording input	Starting emergency recording signal input	
⑬, ⑭	Signal ground		
⑮	Alarm output for available disk space of the copy/-event recording area	Generation of signal output for disk space alarming of the copy/event recording area	Open collector output 24 V DC max., 100 mA
⑯	HDD error output	Signal output upon detection of a HDD error	
⑰	Camera error output	Signal output upon detection of a camera error	
⑱	Error output	Signal output upon detection of a unit error	
⑲	Outage processing end output	Signal output upon completion of outage processing	High (+5 V - +12 V, 6.3 mA max.)
⑳	Time adjustment I/O	The time of this unit is adjusted to the preset time according to the signal input. This signal output is then generated for the setting time of this unit. Time of all other units is adjusted to the setting time of this unit.	52 kΩ 5 V pull-up, Output current –100 mA/Non-voltage make contact input
㉑	NC		
㉒	Alarm suspension input	The state of alarm suspension is assumed according to the signal input.	
㉓	Outage detection input	Start of outage processing according to the signal input.	Non-voltage make contact input 5 V pull-up 150 kΩ
㉔	External recording mode changeover	Changeover to the external recording mode	
㉕	+5 V output	+5 V output	200 mA max.

## ● Connection for emergency recording

When the external switch is turned ON, emergency recording will be started.

Recording time and recording rate for emergency recording differ according to the settings of "Emergency REC" of "Recording" on the SETUP MENU. (Refer to the Setup Instructions (PDF).)

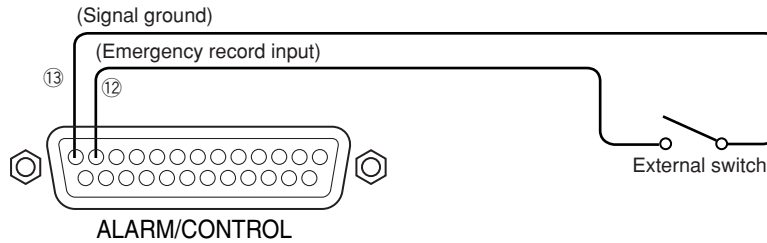

## ● Connection for external recording changeover

When the external switch is turned ON, the recording program changeover is affected for recording.

The recording program can be set by selecting "EXT" for "Time Table" of "Schedule" on the SETUP MENU. (Refer to the Setup Instructions (PDF).)

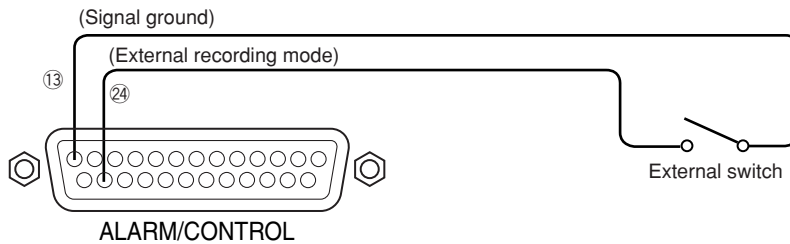

## ● Connection for the Auto Adjust Time function

- When "Auto Adjust Time" of "Time & Date" of "System" on the SETUP MENU is set to "MASTER"

"Time Adjust Output" becomes available and the clock of this unit can be applied to other units.

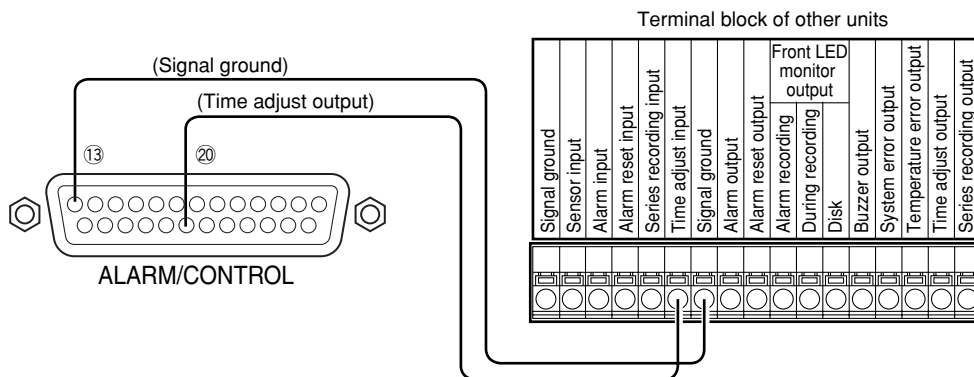

• When "Auto Adjust Time" of "Time & Date" of "System" on the SETUP MENU is set to "SLAVE"

"Time Adjust Input" becomes available. When a signal output from other equipment is supplied to the time adjust I/O terminals between 00 minutes 00 seconds and 14 minutes 59 seconds every hour or between 45 minutes 00 seconds and 59 minutes 59 seconds every hour, the clock will be set to "00 minutes 00 seconds" of the closest hour.

**Example:**

- Signal is supplied at 2:50:00 (hour:minute:second)pm → Set at 3:00:00 pm
- Signal input supplied at 3:14:45 pm → Set at 3:00:00 pm
- Signal is supplied at 3:20:00 pm → Time will not be adjusted.

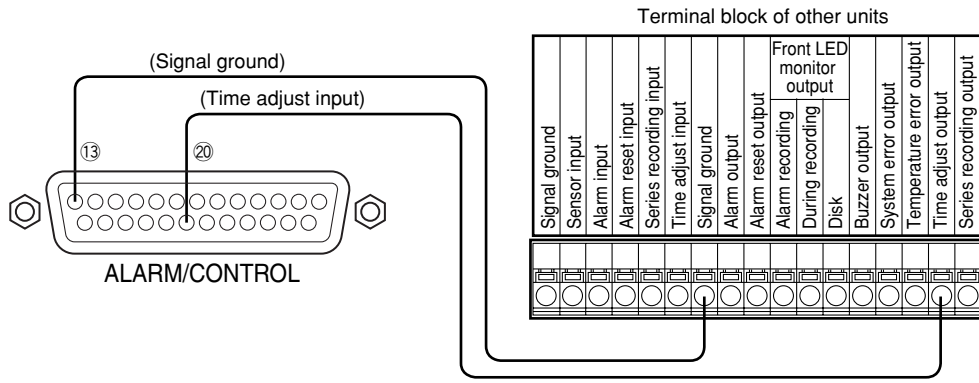

**Important:**

- When "SLAVE" is selected, the auto time adjustment function works differently depending on the recording status as follows:

When no recording is being performed When manual recording is being performed When schedule recording is being performed	The clock will be adjusted.
When event recording is being performed *1 When emergency recording is being performed	The clock will not be adjusted.

\*1: When event recording is performed on any camera channel

## ● Connection with the Uninterruptible Power System (UPS)

This is an example of connection with the uninterruptible power system (UPS) to be installed to protect from a power outage. When a signal is supplied to the outage detection input terminals from the uninterruptible power system (UPS), internal processing (stops recording safely) will be started to shut off the power supply for this unit. After completing the internal processing, a signal will be supplied from the outage processing end output terminal to the uninterruptible power system (UPS). Then, the power supply to this unit can be suspended.

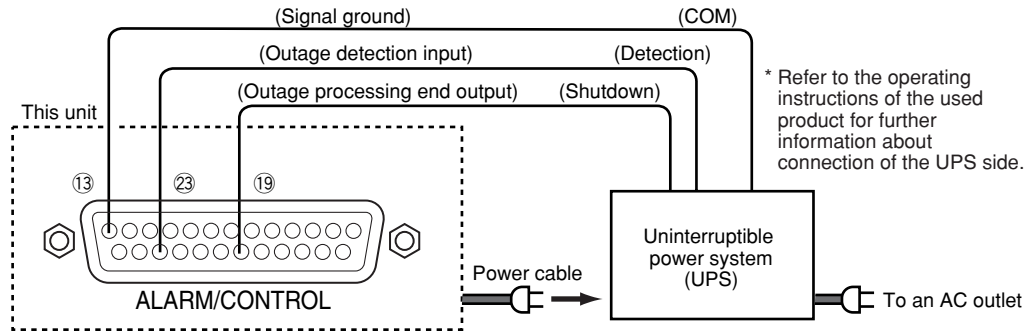

## ● Connection of the control output

- When an alarm device such as a buzzer or a lamp is connected, the signal output from Pin Nos. 15 - 18 can be used to notify the status by sounding a buzzer or lighting a lamp.
- The following example is of a connection with the HDD error output (pin no. 16).

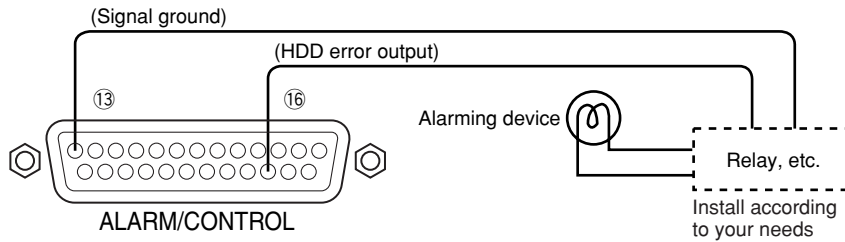

## ■ How to Use the Terminals of the ALARM Connector

These terminals are used to connect the alarm devices, such as sensors, door switches, etc.

The pin configurations of these terminals are as shown below. The connector used should be compatible with the pin configuration.

### Pin Configuration

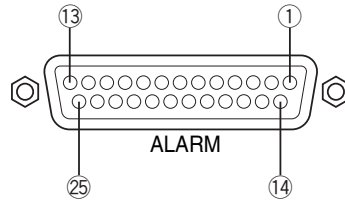

The pin array is different from other disk recorders. Make sure that the connection is correct by referring to the following.

Pin No.	Signal	Operation	Remarks
①	Alarm input 1	Event action will be performed according to the settings.	Non-voltage make contact/ 5 V pull-up 150 kΩ
②	Alarm input 2		
③	Alarm input 3		
④	Alarm input 4		
⑤	Alarm input 5		
⑥	Alarm input 6		
⑦	Alarm input 7		
⑧	Alarm input 8		
⑨	Alarm output 1	Alarm signal will be supplied at an event occurrence	Open collector output/24 V DC max., 100 mA
⑩	Alarm output 2		
⑪	Alarm output 3		
⑫	Alarm output 4		
⑬, ⑭	Signal ground		
⑮	Alarm input 9	Event action will be performed according to the setting.	Non-voltage make contact input/ 5 V pull-up 150 kΩ
⑯	Alarm input 10		
⑰	Alarm input 11		
⑱	Alarm input 12		
⑲	Alarm input 13		
⑳	Alarm input 14		
㉑	Alarm input 15		
㉒	Alarm input 16		
㉓	Alarm output 5	Alarm signal will be supplied at an event occurrence	Open collector output/24 V DC max., 100 mA
㉔	Alarm output 6		
㉕	Alarm output 7		

**Note:** Refer to page 18 about "Alarm output 8-16".

## ● Alarm connection

When a signal is supplied to the alarm input terminals recording and displaying of camera images will be performed according to the settings.

When an alarm device such as a buzzer, a lamp, etc., is installed outside, connect them to the alarm output terminals (pin nos. 9 - 12, pin nos. 23 - 25) or to the alarm output terminals (pin nos. 1 - 9) of the ALARM/CONTROL terminal.

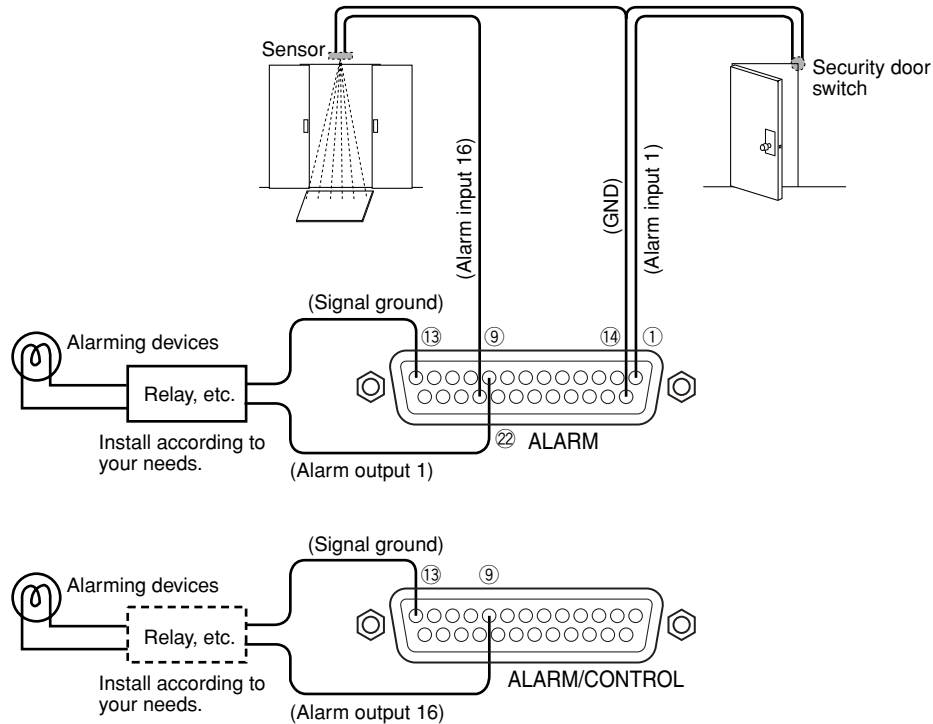

Time and polarities of the ALARM/CONTROL terminal and the ALARM terminal

Terminal	Active time	Note
Alarm input	100 ms or more	N.O.: L active N.C.: H active
Alarm output	The set time on the SETUP MENU	L active
Network error output	Until the network error is cleared, or until the ALARM RESET button on the operation window is clicked.	L active
Alarm reset input	100 ms or more	L active
Emergency recording input	100 ms or more	L active
Alarm output for available disk space of the copy/event recording area	While the size of the available disk space is less than the set size	L active
HDD error output	From the time of the error occurrence until the sounding buzzer is reset	L active
Camera error output	From the time of the error occurrence until the sounding buzzer or the camera is reset	L active
Error output	From the time of the error occurrence until the sounding buzzer is reset	L active
Outage processing end output	1 s or more	H active
Time adjustment I/O	Input: 100 ms or more Output: 1 s	L active
Alarm suspend input	100 ms or more	L active, judged by level
Outage detection input	5 s or more	L active
External recording mode changeover	100 ms or more	L active

# How to Replace Hard Disk Drives

Replacement of hard disk drives is available regardless of whether the power of the unit is on or off.

The procedure of replacement depends on whether the power of the unit is on or off.

Refer to the operating instructions for the optional extension unit when replacing the hard disk in the extension unit.

## When replacing the hard disk drive with the unit power off

Turn off the power of the unit and detach the power plug from the outlet.

1. Open the connectors cover on the front panel and remove the fixing screw.  
Detach the front panel by sliding it after removing the screw.

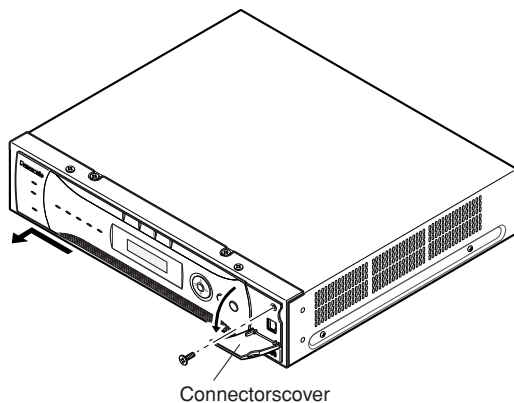

### Important:

- Do not detach the cable connecting the unit and the front panel while the HDD status indicators are still lit or until 30 seconds have passed since the HDD status indicators went off.
- Protect the hard disk drives from static electricity.
- Do not stack them, or keep them upright.
- Do not use an electric screwdriver to secure them. (Tightening torque: 0.49 N·m {5 kgf·cm})
- Avoid rapid changes in the temperature and humidity to prevent condensation. (Acceptable change: within 15 °C/h {59 °F/h})

2. Remove the connector from the front panel.

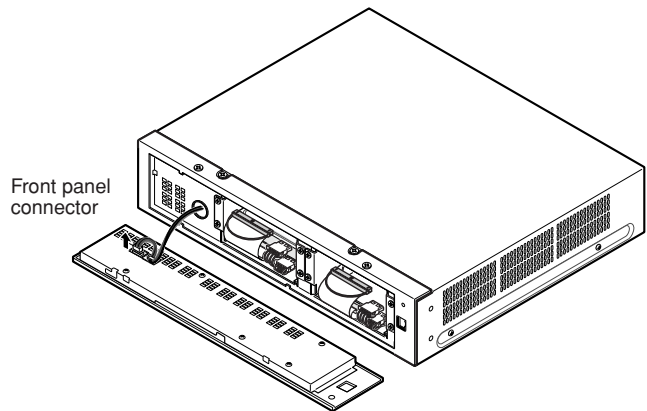

### Important:

- Do not pull the cable.
- Hold the connector and pull it straight up.

3. Remove two cables connecting to the hard disk drive.

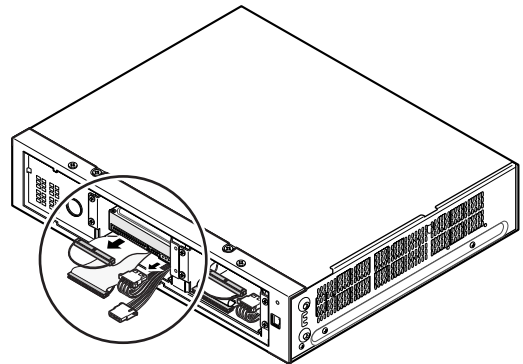

4. Remove both of the hard disk drive units.

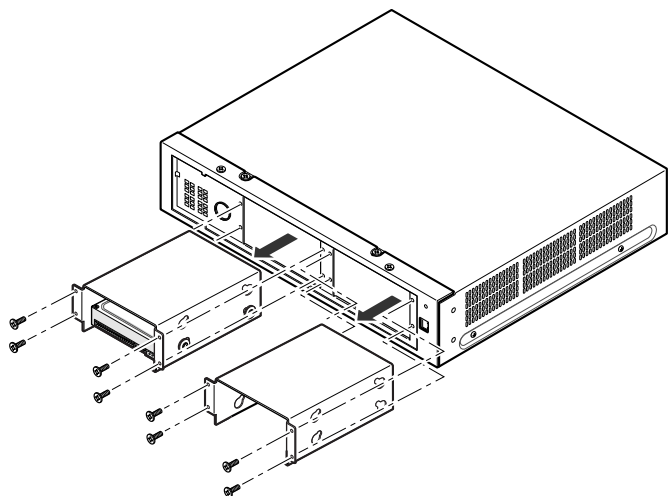



- Remove the screws (4 for each drive unit) and pull the drive units out.
- Avoid missing the screws for reattaching.
- \* For replacement of hard disk drives, remove the hard disk drives from the brackets respectively.

5. Make preparations for the hard disk drives.

- Discharge static electricity from your body before handling the hard disk drives.
- Place the conductive bag in which the hard disk drive has been put on a soft material such as a mat, and put the hard disk drive with the board side facing down on the bag to protect the drive from static electricity.

6. Secure the hard disk drives to the brackets respectively.

- Use 4 sleeves and 4 dampers that are supplied for each drive unit to secure the drives.
- Do not use an electric screwdriver for impact prevention. (Tightening torque: 0.49 N·m {5 kgf·cm})

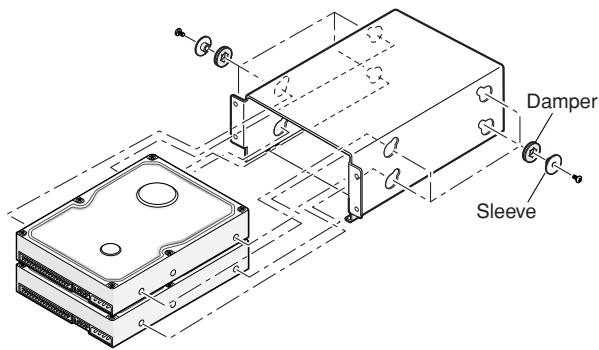

7. Set all the jumper connectors to the master side.

- Refer to the instruction manual attached to the hard disk drive for details.

8. Mount the hard disk drives on the extension unit.

- Use the screws that had been removed in Step 4.
- Do not use an electric screwdriver for impact prevention. (Tightening torque: 0.784 N·m {8 kgf·cm})

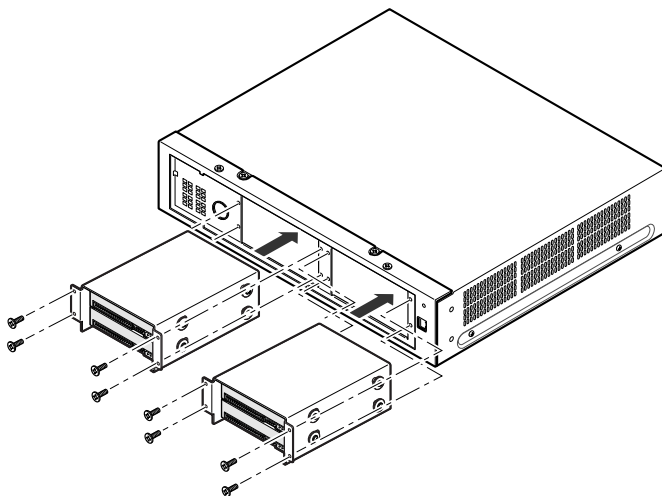

**Important:**

The identification numbers of the built-in hard disk drives are assigned as shown below. The following are the relationship between slot numbers and hard disk drive numbers.

**Slot HDD #1 :** HDD1

**Slot HDD #2 :** HDD2

**Slot HDD #3 :** HDD3

**Slot HDD #4 :** HDD4

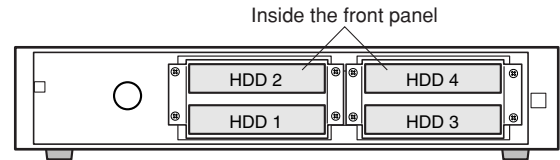

Make sure to follow the mounting order of hard disk drives, HDD1 -> HDD2 -> HDD3 -> HDD4.

Failure to observe this disables the hard disk drives because a digital disk recorder cannot identify the drives.

9. Connect the cables.

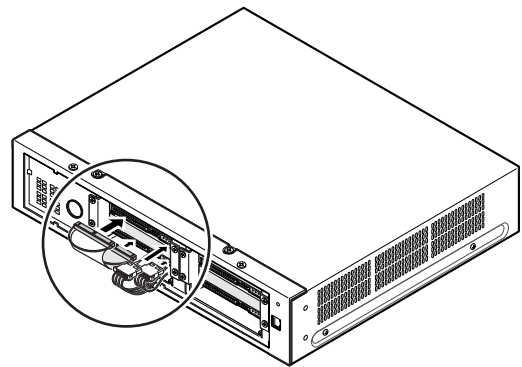

10. After completion of replacement, connect the power plug to the outlet and turn on the power of the unit.

→ The disk configuration menu automatically appears after starting up the unit.

## When replacing the hard disk drive with the unit power on

- 1 Call up the "HDD Setup" display on the LCD, and press the [SET] button.  
The following menu will be displayed on the LCD.

```
HDD Mode Setup
RAID5 <NO/YES>
```

- 2 Press the arrows button (▼ or ▲) repeatedly until the following menu is displayed.

```
HDD Safety Mode
ACCEPT <NO/YES>
```

- 3 Select "YES" and press the [SET] button.  
The following menu will be displayed and the power of the hard disk drive will be turned off automatically.

```
HDD Safety Mode
Wait for 30sec
```

- 4 Wait for around 30 seconds until the following menu is displayed.

```
HDD Safety Mode
REBOOT/PANEL OFF
```

- 5 Select "PANEL OFF" and press the [SET] button.  
The OPERATE indicator and the LCD display will go off.  
(The front panel is inoperable since the power supply to the front panel is stopped now.)
- 6 Detach the front panel and replace the hard disk drive.  
Refer to page 24 for descriptions of how to replace the hard disk drive.  
(When replacing the hard disk drive of the extension unit, it is necessary to detach the front panel in the same way as described above. Refer to the operating instructions for descriptions of how to replace the hard disk drive of the extension unit.)

### Important:

When detaching the front panel, confirm that the OPERATE indicator on the front panel is off.

- 7 After completing the HDD replacement, attach the cable to the front panel. The OPERATE indicator will light and the following menu will be displayed on the LCD.

```
FRONT PANEL DET.
REBOOT <YES>
```

- 8 Press the [SET] button.  
The unit will reboot. The following menu will be displayed.

```
HDD Safety Mode
OFF /PANEL OFF
```

- 9 Select "OFF" and press the [SET] button.  
The unit will reboot and the time and date display (standby display) will be displayed.
- 10 Start the web browser.  
After the browser starts, enter the IP address set to this unit in the address box, and press the enter key.  
The disk configuration menu will be displayed.  
Configure the disk settings according to your need.  
Refer to the Setup Instructions (PDF) for how to operate the disk configuration menu.

# Turn On/Off the Power of the Unit

## Operating the Unit for the First Time

### Important:

- When connecting an optional extension unit (WJ-HDE300 series), turn on the power of the extension unit before turning on this unit.

### 1. Turn on the POWER switch.

The OPERATE indicator will light and the system check (checking the system and hard disk) will start.

The "WJ-ND300A" indication will be displayed on the LCD at startup, and the "Initializing" indication will be displayed while checking the system. When the system check is complete, the time and date display (standby display) will be displayed on the LCD.

### 2. Display the HDD DISK MENU.

After the browser starts, enter the IP address set to this unit in the address box, and press the enter key. The HDD DISK MENU will be displayed. Perform the settings with this menu according to your needs. Refer to the Setup Instructions (PDF) for descriptions of how to operate the HDD DISK MENU.

## Turn on the Power of the Unit

### 1. Insert the power plug to an outlet.

120 V AC 60 Hz, for NTSC model  
220 V - 240 V AC 50 Hz for PAL model

**Note:** Make sure the power source matches the power requirement of the model in use.

### 2. Turn on the POWER switch on the rear of the unit.

The OPERATE indicator will light and the system check (checking the system and hard disk) will start.

The "WJ-ND300A" indication will be displayed on the LCD at startup, and the "Initializing" indication will be displayed while startup. Then, the "System Checking" indication will be displayed while checking the system. When the system check is complete, the time and date display (standby display) will be displayed on the LCD.



W J - N D 3 0 0 A

Startup display

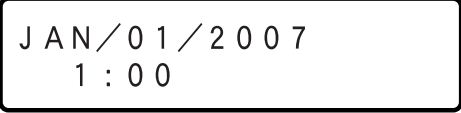

J A N / 0 1 / 2 0 0 7  
1 : 0 0

Time and date display (Standby display)

### Important:

When using the optional extension unit (WJ-HDE300 series), turn on the power of this unit after turning on the power of all extension units.

# Turn off the Power of the Unit

To shutdown the unit, do the following.

## 1. When the manual recording is being performed, stop the recording.

Click the  button in the [REC] box displayed when the [HDD] tab is selected.

The  button and the  button will be displayed.

Click the  button to stop manual recording.

Refer to the Setup Instructions (PDF) for details.

## When playing back recorded pictures, stop the playback.

Click the  button displayed when the [HDD] tab is selected.

Refer to the Setup Instructions (PDF) for details.

## 2. Turn off the POWER switch on the rear of the unit.

Turn off the power of the unit after confirming that all the HDD access indicators are off.

### Important:

- Detach the plug from the outlet if not operating the unit for a length of time.
- When the unit has not been used for a certain period, turn on the power of the unit (approximately once a week), and perform recording/playback to prevent interferences with functions.

# Operation Using the Buttons on the Front Panel

The following are the available functions using the buttons on the front panel and the LCD. The display on the LCD will shift as follows by pressing the arrows button (▼ or ▲).

JAN / 01 / 2007  
1 : 00

▼ Arrows buttons ▲

Temperature  
32° C

(Temperature will be displayed in Fahrenheit for NTSC model, e.g. "90 °F".)

▼ Arrows buttons ▲

IP Address Check  
[SET]

▼ Arrows buttons ▲

IP Address Setup  
[SET]

▼ Arrows buttons ▲

Keylock Mode  
[SET]

▼ Arrows buttons ▲

HDD Setup  
[SET]

▼ Arrows buttons ▲

Manual Reboot  
[SET]

## Time and date display (Standby display)

The current time will be displayed.

Refer to the Setup Instructions (PDF) for descriptions of how to change the time format and adjust the time and date.

## Temperature display

The current internal temperature of the unit will be displayed.

When exceeding the specified temperature, the "WARNING" indication will be displayed.

## IP address check display

The network settings can be checked with this display.

Press the [SET] button on the front panel while displaying this display.

It is possible to check each network setting such as the IP address or the subnet mask.

Refer to page 30 for details.

## IP address setup display

The network settings can be set with this display.

Press the [SET] button on the front panel while displaying this display.

It is possible to set each network setting such as the IP address or the subnet mask.

Refer to page 31 for details.

## Key lock mode display

It is possible to lock the buttons on the front panel to make them unusable.

Refer to page 32 for details.

## HDD setup display

It is possible to carry out each maintenance function after activating the HDD safety mode using this display.

Refer to page 33 for details.

## Manual reboot display

It is possible to reboot the unit using this display.

Refer to page 35 for details

# Check the Network Settings

It is possible to check the following network settings.

- DHCP
- IP address
- Subnet mask
- Gateway\*<sup>1</sup>
- HTTP port\*<sup>1</sup>

To check each setting, shift the display as follows.

**Note:** To change the port number (PT#), press the arrows button (◀ or ▶).

- Camera port (PT#1)
- Client PC port (PT#2)
- Maintenance port (PT#3)

\*1: The settings of "Gateway" and "HTTP port" can be checked by displaying the client PC port (PT#2).

	Camera port	Client PC port	Maintenance port
DHCP	OFF	OFF	–
IP address	192.168.0.250	192.168.1.250	192.168.2.250
Subnet mask	255.255.255.0	255.255.255.0	255.255.255.0
Gateway	192.168.1.1		–
HTTP port	–	80	–

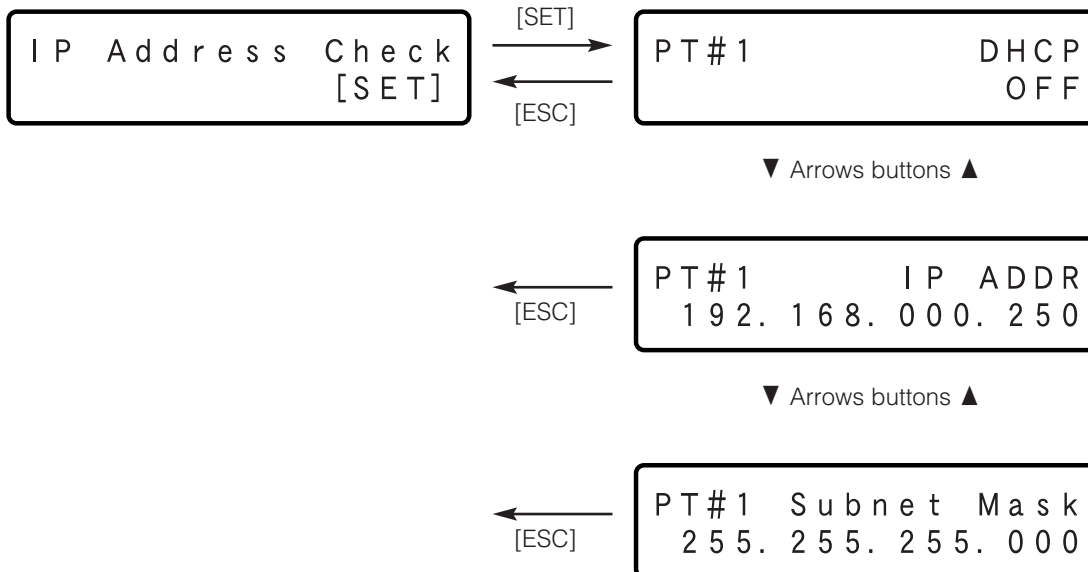

# Set the Network Settings

It is possible to set the network settings. The available settings items are the same as described in the "Check the Network Settings" section on the previous page.

It is possible to shift the display by pressing the arrows button (▼ and ▲) while the underscore mark ( \_ ) is displayed below the ">" indication.

Shift the display and configure each setting as described below.

The settings of "Gateway" and "HTTP port" can be configured when displaying the "PT#2" indication (client PC port).

**Note:** To change the port number (PT#), press the arrows button (◀ or ▶) while the underscore mark ( \_ ) is displayed below the ">" indication.

- Camera port (PT#1)
- Client PC port (PT#2)
- Maintenance port (PT#3)

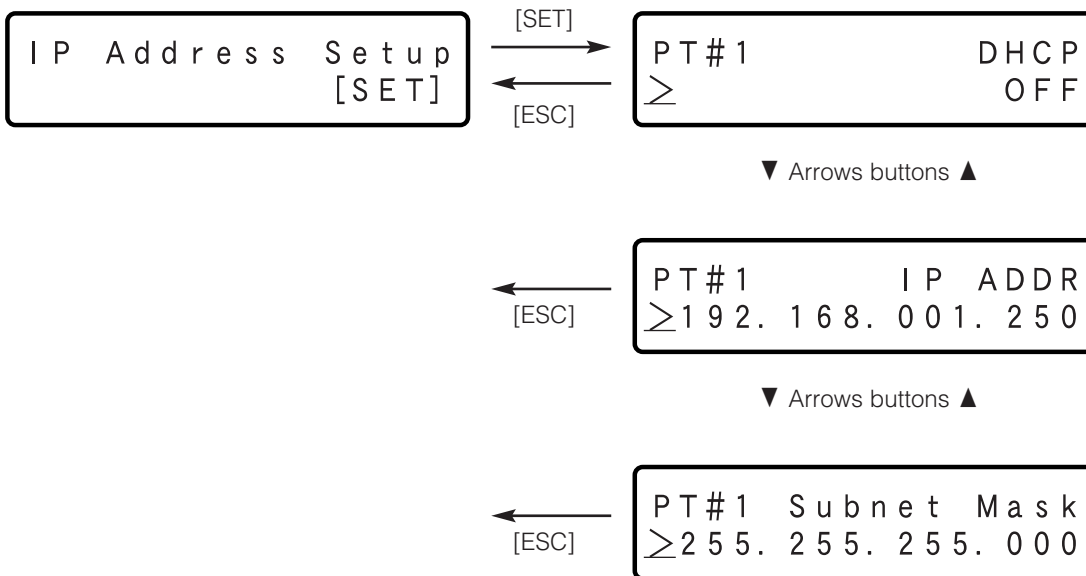

**1. Move the underscore mark below the number to be edited.**

The underscore mark will move below the number by pressing the [SET] button while the underscore mark is displayed below the ">" indication.

**2. Enter the desired values.**

**Move the underscore mark:** Arrows button (◀ and ▶)

**Enter values:** Arrows button (▼ and ▲)

**Important:**

Network settings for each port (IP address, etc.) should be on a different subnet. Otherwise, network communication may be failed.

**3. Move the underscore mark below the ">" indication by pressing the [ESC] button.**

The edited settings will be determined.

**4. Configure the network settings of another network port.**

Change the port number (PT#) by pressing the arrows button (◀ or ▶) while the underscore mark ( \_ ) is displayed below the ">" indication.

The port number indication will change each time the arrows button (◀ or ▶) is pressed.

- PT#1:** Camera port
- PT#2:** Client PC port
- PT#3:** Maintenance port

## Key Lock Settings

It is possible to lock the buttons on the front panel to make them unusable.

When the [SET] button is pressed while displaying the key lock display, the message of "Keylock Enabled" will be displayed and the buttons on the front panel will be locked.

The time and date display (standby display) will be displayed soon after the buttons are locked.



To release the key lock, press any button on the front panel.

The LCD will display the password box.

Enter the password that has set for "Front panel key lock" of "Basic Setup" under "System" on the SETUP MENU.

When the password is confirmed, the locked buttons will be released.

**Note:**

Default password: 12345

## Set the HDD Mode

The following HDD modes are available for maintenance.

- RAID 5 mode settings [RAID5]  
Set to the RAID 5 setting.
- Single mode settings [SINGLE]  
Release the RAID 5 mode and set to the single mode.
- HDD recovery [RECOVERY]  
Perform the HDD recovery after replacing the HDD when one of the RAID disk failed.
- RAID board initialization [INIT.]  
Initialize the RAID board. It is necessary to initialize the RAID board when changing the mode between the RAID 5 mode and the single mode, and when the HDD failure caused "2 DOWN" of RAID.
- HDD safety mode [HDD Safe Mode: ACCEPT]  
When maintaining (HDD replacement, installation, etc.) without turning the power of the unit off, activate the HDD safety mode.
- Unit number (of the extension unit) check [EXT Number Check]  
Unit number of the connected extension unit number will be displayed.



Shift the display on the LCD using the arrows button (▼ and ▲).

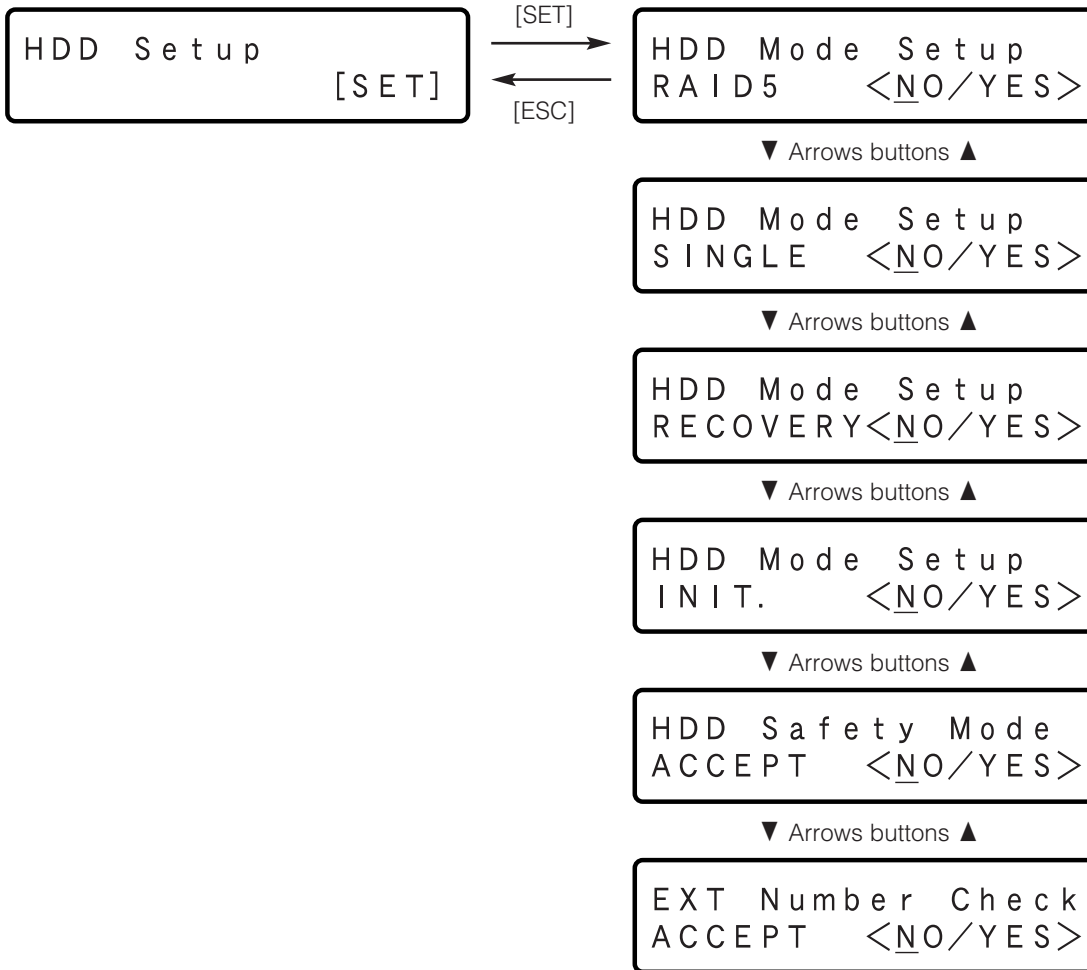

**Important:**

When the HDD safety mode is activated, the power of the all HDDs will be off. (Recording and playback will be forcibly canceled.)

## Execute Each Maintenance Function

**1. Press the [SET] button after selecting "YES" on the desired maintenance function display.**

The message "ACCEPT" will be displayed on the LCD when the [SET] button is pressed after moving the underscore mark below "YES" using the arrows button (◀ or ▶).

When the [SET] button is pressed after selecting "NO", returns to the previously displayed menu.

**2. Press the [SET] button after selecting "YES" when "ACCEPT" is displayed.**

The power of all HDDs will be turned off automatically and each menu item will be carried out when the [SET] button is pressed after moving the underscore mark below "YES" using the arrows button (◀ or ▶).

The unit will restart when "RAID5", "SINGLE", "RECOVERY" or "INIT." is carried out.

The power of all HDDs will be turned off when the "HDD safety mode" is activated.(It takes approx.30 sec until the power is turned off.) When the power of the HDDs is turned off, the unit can be installed in the rack without turning the power of the unit off, and HDD replacement becomes possible. Consult your dealer for HDD replacement.

When "EXT Number Check" is carried out, the confirmation indication for unit number 1 will be displayed after around 30 seconds.

When the [SET] button is pressed while displaying this indication, the HDD access indicators of the respective extension unit will light red for around 5 seconds. Refer to page 35 for further information.

When the [SET] button is pressed after selecting "NO", the previous display will appear on the LCD.

# Set the HDD Safety Mode

When installing/uninstalling the unit in the rack without turning the power of the unit off, do the following. (Steps 1, 3 and 4.)

## 1. Turn off the power of the HDDs.

Press the [SET] button after selecting "YES" when the "ACCEPT" indication is displayed (page 32).

When the [SET] button is pressed, the "Wait for 30 sec" indication will be displayed.

When the power of the HDD is turned off (it will take for around 30 seconds), the "REBOOT/PANEL OFF" indication will be displayed.

Press the [SET] button after selecting "YES".

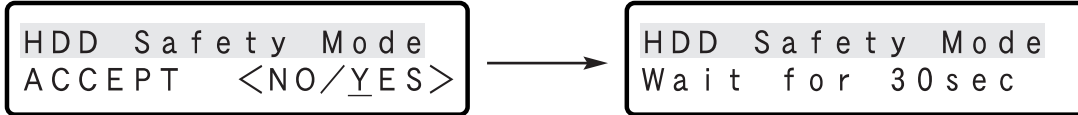

After around 30seconds



### Important:

- Installation of the unit should be made while the "REBOOT/PANEL OFF" indication is displayed on the LCD. After completing the installation, perform step 2.
- To replace the HDDs, perform steps 3 and 4.

## 2. Reboot the unit.

Press the [SET] button after selecting "REBOOT" using the arrows button (◀ and ▶) when the "REBOOT/PANEL OFF" indication is displayed.

The unit will restart.

## 3. Detach the front panel.

Press the [SET] button after selecting "PANEL OFF" using the arrows button (◀ and ▶) when the "REBOOT/PANEL OFF" indication is displayed.

The OPERATE indicator and the LCD will go off.

### Important:

Detach the front panel after confirming that the OPERATE indicator and the LCD are went off. If the front panel is detached while the OPERATE indicator or the LCD is on, it may damage the unit. Consult your dealer for the front panel detachment and HDD replacement.

## 4. Attach the front panel and restart the unit.

When the front panel is attached correctly, the following indication will be displayed. The unit will restart by pressing the [SET] button.



# Check the Unit Number of the Extension Unit

The unit number of the connected extension unit can be checked with the HDD access indicators on the extension unit.

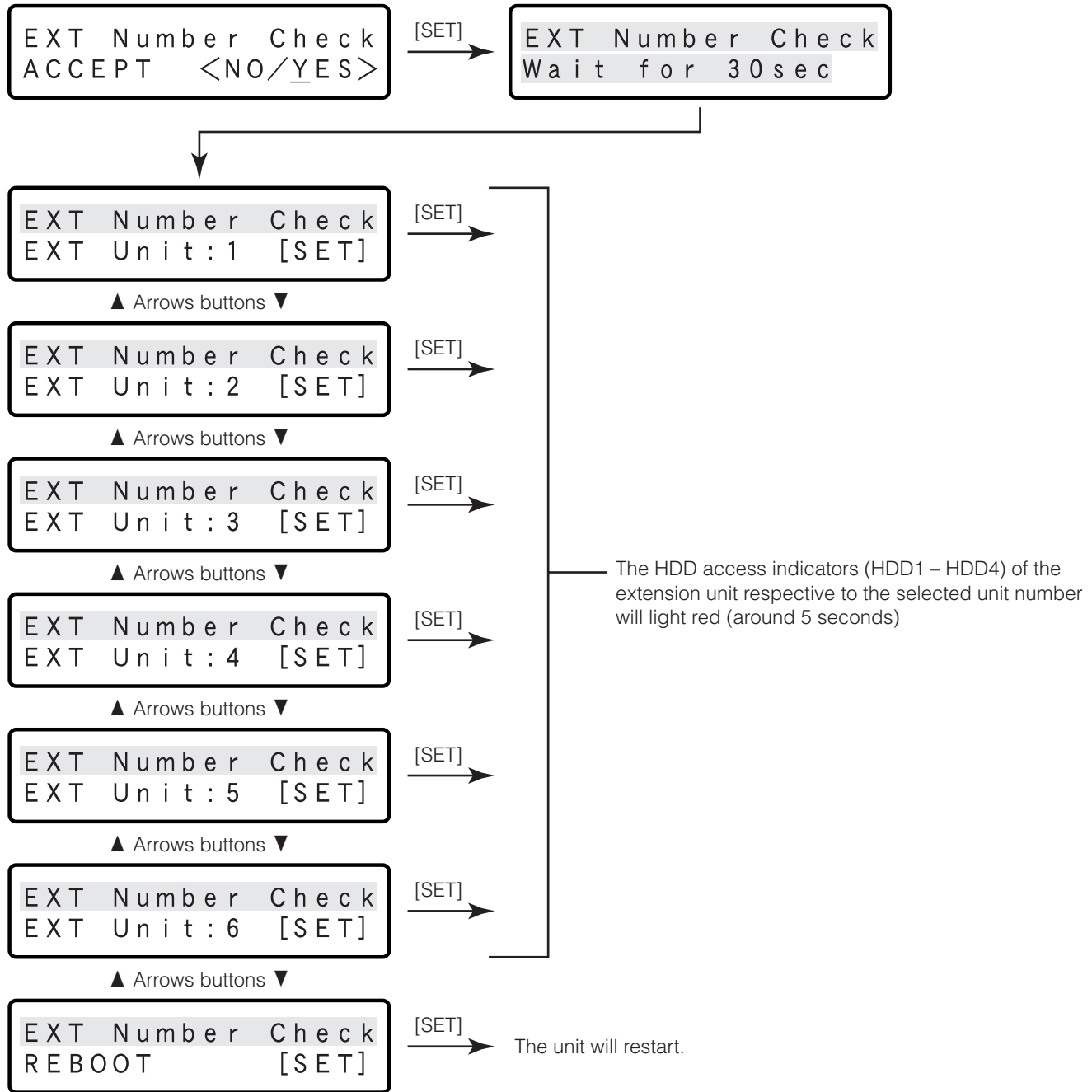

**1. Select "YES" when the "EXT Number Check" indication (page 33) is displayed on the LCD, and then press the [SET] button.**

The message "Wait for 30 sec" will be displayed. When the unit completed to turning off the power of the HDDs (it will take around 30 seconds), the "EXT Unit:1" will be displayed.

**2. Check the unit number of the extension unit.**

When the [SET] button is pressed while the "EXT Unit:1" indication is displayed, the HDD access indicators (HDD1 - HDD4) of the extension unit with unit number 1 will light red for around 5 seconds.

The displayed unit number can be shifted to the other unit number using the arrows button (▼ or ▲).

**3. Quit the unit number check.**

Display "Reboot" by pressing the arrows button (▼ or ▲), and then press the [SET] button. The unit will restart.

# Reboot the Unit Manually

It is possible to reboot the unit manually as follow.  
Press the [SET] button while displaying the [REBOOT] display.  
The message "ACCEPT" will be displayed.

When the [SET] button is pressed after moving the underscore mark below "YES" using the arrows button (◀ or ▶), the unit will reboot.

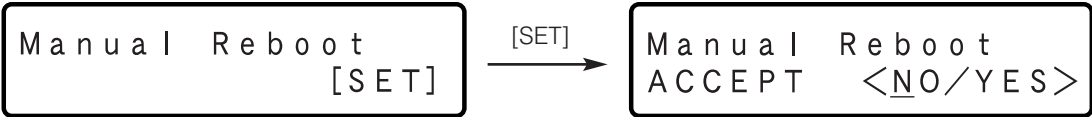

# Troubleshooting

## Check the following before requesting repair

Contact a dealer if a problem cannot be solved even after checking and trying the solution or if a problem is not described below, or when having a problem with installations.

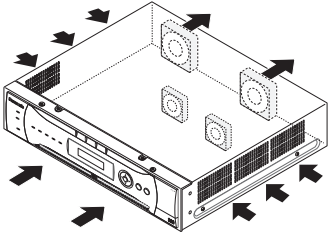
Problem	Check item/Remedy	Page
<p>Power is not turned on.</p>	<ul style="list-style-type: none"> <li>• Check if the power plug is properly connected to the AC outlet.</li> </ul>	-
	<ul style="list-style-type: none"> <li>• Check if the power cord is properly inserted into the power socket of the unit.</li> </ul>	-
<p>Alarm operations are not activated.</p>	<ul style="list-style-type: none"> <li>• Check if alarm input signals are properly input to the ALARM or ALARM/CONTROL at the rear panel.</li> </ul>	18, 22
	<ul style="list-style-type: none"> <li>• Check the settings of the ALARM connector.</li> </ul>	22
<p>The error indicator blinks orange.</p> <p>The unit stops because of the thermal error.</p>	<ul style="list-style-type: none"> <li>• The fan is not functioning because of the malfunction. Refer to the dealer.</li> </ul>	6
	<ul style="list-style-type: none"> <li>• Aren't the fans on the rear or the ventilation slots on the front and both sides of the unit blocked?</li> </ul> 	6
	<ul style="list-style-type: none"> <li>• Temperature inside the unit is too high/low. Use the unit at appropriate ambient temperatures.</li> </ul>	6
	<ul style="list-style-type: none"> <li>• When the error indicator lights orange, temperature inside the unit may be too high. Check whether dust is collected around the fans or not.</li> </ul>	6, 10
<p>The HDD access indicator lights/blinks red.</p>	<ul style="list-style-type: none"> <li>• The respective HDD is failed in the RAID 5 mode. The indicator respective to the HDD that failed first will light red and the indicators for the other failed HDD will blink red.</li> </ul>	10

Problem	Check item/Remedy	
<p>The HDD access indicator lights red and orange.</p>	<ul style="list-style-type: none"> <li>• The system error occurred. Refer to the dealer.</li> <li>The system error status will be displayed with the HDD indicators as follows.</li> <li>● : Red, ○ : Orange</li> <li>○ ● ● ● : Hardware malfunction</li> <li>● ○ ● ● : Hardware malfunction</li> <li>○ ○ ● ● : Hardware malfunction</li> <li>● ● ○ ● : Hardware malfunction</li> <li>○ ● ○ ● : Hardware malfunction</li> <li>● ○ ○ ● : Hardware malfunction</li> <li>○ ○ ○ ● : Hardware malfunction</li> <li>● ● ● ○ : Hardware malfunction</li> <li>○ ○ ● ○ : Hardware malfunction</li> <li>● ● ○ ○ : Hardware malfunction</li> <li>● ○ ○ ○ : Disk CRC error</li> </ul>	<p style="text-align: center;">-</p>

**Inspect the power cord, power plug and connectors periodically.**

Problem	Check item/Remedy	
<p>The power cord insulation is damaged.</p>	<ul style="list-style-type: none"> <li>• The power cord, plug and connectors are worn out. This may result in electric shock or a fire. Unplug the power plug from the AC outlet immediately, and refer to qualified service personnel.</li> </ul>	
<p>The power cord, plug and connectors get hot during use.</p>		
<p>The power cord gets hot when bent or stretched.</p>		

# Specification

## General

Power source	NTSC model: 120 V AC, 60 Hz PAL model: 220 V - 240 V AC, 50 Hz
Power consumption	85 W
Ambient operating temperature	5 °C to 45 °C {41 °F - 113 °F}
Ambient operating humidity	5 % - 90 % (non condensing)
Maximum operating altitude	2 000 m (6 562 feet) above sea level
Dimensions	420 mm (W) x 88 mm (H) x 350 mm (D) {16-9/16" (W) x 3-7/16" (H) x 13-3/4" (D)} (excluding rubber feet and projections)
Weight	8.3 kg {18.3 lbs.}

## Input/Output

External storage	High-speed serial interface, 480 Mbps (theoretical value), x1
Alarm/Control connector	Emergency recording input *1, Alarm output for available disk space of the copy/event recording area*2, HDD error output*2, Camera error output*2, Error output*2, Power outage recovery completion output*1, Time adjustment input/output*4, Power outage detection input*1, External recording mode switching*1, Alarm output 8-16*2, Alarm suspension input*1, Alarm reset input*1, Network error output*2, +5 V output*5 (D-sub 25-pin)
Alarm connector	Alarm input 1-16*1, Alarm output 1-7*2 (D-sub 25-pin)
Camera port/client PC port	10Base-T/100Base-TX (RJ-45)
Maintenance port	10Base-T (RJ-45)

\*1: Non-voltage make contact, +5 V pull-up 150 k $\Omega$

\*2: Open collector output, 24 V DC max., 100 mA

\*3: HIGH (+5 V - +12 V, 6.3 mA max.)

\*4: 52 k $\Omega$ , 5 V pull-up, Output current –100 mA/Non-voltage make contact input

\*5: 200 mA max.

# Standard Accessories

CD-ROM*	1 pc.
Installation Guide (this manual)	1 pc.
The following are for installation:	
Power Cord (NTSC model)	1 pc.
Power Cord (PAL model)	2 pcs.
Rack Mounting Bracket	2 pcs.
Screw for Rack Mounting Bracket	4 pcs.
Hard Disk Drive Fixing Screw (w/sleeve and damper).	12 pcs.

\* The CD-ROM contains the operating instructions (PDFs) and the setup tools (Panasonic IP setup software, etc.).

### Information on Disposal for Users of Waste Electrical & Electronic Equipment (private households)



This symbol on the products and/or accompanying documents means that used electrical and electronic products should not be mixed with general household waste.

For proper treatment, recovery and recycling, please take these products to designated collection points, where they will be accepted on a free of charge basis. Alternatively, in some countries you may be able to return your products to your local retailer upon the purchase of an equivalent new product.

Disposing of this product correctly will help to save valuable resources and prevent any potential negative effects on human health and the environment which could otherwise arise from inappropriate waste handling. Please contact your local authority

for further details of your nearest designated collection point.

Penalties may be applicable for incorrect disposal of this waste, in accordance with national legislation.

### For business users in the European Union

If you wish to discard electrical and electronic equipment, please contact your dealer or supplier for further information.

### Information on Disposal in other Countries outside the European Union

This symbol is only valid in the European Union.

If you wish to discard this product, please contact your local authorities or dealer and ask for the correct method of disposal.

#### For U.S., Canadian and Puerto Rican fields:

**Panasonic System Solutions Company,**  
Unit Company of Panasonic Corporation of North America

**Security Systems**  
[www.panasonic.com/security](http://www.panasonic.com/security)  
For customer support, call 1.877.733.3689

**Executive Office:** Three Panasonic Way 2H-2, Secaucus, New Jersey 07094

**Zone Office**  
**Eastern:** Three Panasonic Way, Secaucus, New Jersey 07094  
**Central:** 1707 N. Randal Road, Elgin, IL 60123  
**Southern:** 1225 Northbrook Parkway, Suwanee, GA 30024  
**Western:** 6550 Katella Ave., Cypress, CA 90630

**Panasonic Canada Inc.**  
5770 Ambler Drive, Mississauga,  
Ontario, L4W 2T3 Canada (905)624-5010  
<http://www.panasonic.ca>

**Panasonic Sales Company**  
Division of Panasonic Puerto Rico Inc.  
San Gabriel Industrial Park 65th Infantry Ave. KM. 9.5 Carolina  
P.R. 00985(809)750-4300

#### For European and other fields:

**Matsushita Electric Industrial Co., Ltd.**

Osaka, Japan  
<http://panasonic.net>